

HG-702

Water Quality Analyzer



Version 5.00

January 2007

1 Preface

1.1 *Intended Use*

This manual is for qualified and trained service technicians who will install and service the HydroGuard HG-702 Water Quality Analyzer. It provides instructions on how to install the HydroGuard system, how to integrate it with external chemical dosing systems, as well as how to calibrate, operate, and maintain the system.

Safety Precautions

Warning: Only properly trained and licensed electricians should attempt to wire or service the electronic components of the analyzer. There is an Electrical Shock Hazard when servicing this system. Always verify that all electrical power source(s) are off before opening the analyzer unit or attempting to service electronic components or wiring.

Caution: Extreme caution should be used when installing, operating, and maintaining the HydroGuard HG-702 Water Quality Analyzer and Controller. Only properly trained technicians are authorized to install and maintain the analyzer. Only properly trained and licensed electricians should attempt any change to the system's electrical components. Only properly trained and licensed operators should attempt to make any changes to chemical dosing levels.

Always follow local health and safety regulations when performing any service on the HydroGuard unit or changing chemical dosing settings.

No part of this publication may be reproduced, transmitted, transcribed, stored in a retrieval system, or translated into any language or any computer language, in any form or by any third party, without the prior written permission of Blue I Water Technologies Ltd.

Trademarks and Patents

HydroGuard is the Registered trademark of Blue I Water Technologies Ltd.
Patents issued and pending at the time of this printing

Disclaimer

Blue I Water Technologies Ltd. does not accept any responsibility for any damage caused to its products by unauthorized personnel. Use of non-Blue I Water Technologies' reagents and/or replacement parts will void all warranties.

Table of Contents

1	Preface	2
1.1	Intended Use	2
1.2	Overview of Chapters	5
2	Overview.....	5
2.1	The HydroGuard Solution.....	5
2.2	Measurements and Features.....	6
2.2.1	Wireless Management Package*.....	6
2.3	System Components	6
3	Installation	9
3.1	Selecting a Location	9
3.2	Site Requirements and Installation.....	9
3.2.1	Mechanical Installation.....	9
3.3	Plumbing Requirements and Installation.....	10
3.3.1	Water Supply	10
3.3.2	Drainage	10
3.4	Electrical Requirements and Installation	11
3.4.1	Connecting the Main Electrical Power	11
3.4.2	Input Switches.....	12
4	First Time Operation and Calibration	13
4.1	Installing additional Sensors and Meters.....	13
4.2	Installing Reagents	13
4.3	First Time Menu Setup	14
4.3.1	HydroGuard Control Panel	14
4.3.2	Menus	15
4.3.3	Configuring Settings in the Operator Menu	18
4.4	Calibration.....	18
4.4.1	Chlorine Calibration	18
4.4.2	Calibrating other Sensors and Meters	19
4.5	Technician Menu Setup.....	19
4.5.1	Configuring Settings in the Technician Menu	22
4.6	Menu Feature Description	22
4.7	Calibration and Initial Operation Checklist	23
5	Routine Operation and Maintenance	24
5.1	Monitoring HydroGuard Alarms.....	25
5.2	Replacing Reagents	26
5.3	Cleaning the Filter	26
5.4	Shut-Down and Winterizing	26
5.5	Start-up and Preventive Maintenance	27
5.5.1	Replacing Reagent Pump Head and Tubes	27
5.6	Troubleshooting	27
5.7	Replacing Components	30
5.7.1	Replacing Flow Switch.....	30
5.7.2	Replacing Reagent Siphons	30
5.7.3	Replacing the reagent level sensor	30
5.7.4	Replacing Reagent Pumps	30
5.7.5	Replacing Colorimeter	31
5.7.6	Replacing Colorimeter Solenoid Valve	31
5.7.7	Replacing Control Panel Module (electronics card)	32
5.7.8	Replacing I/O Module	32
5.7.9	Replacing Colorimetric Module.....	32
5.7.10	Module Software Update	32
6	Additional Measurements and Features	33

6.1	Additional Measurements	33
6.2	Free + Total Chlorine Measurements.....	33
6.2.1	Installation	33
6.2.2	Installing DPD3 Reagent	33
6.2.3	Additional Menus and First Time Set-up.....	34
6.2.4	Activate Total Chlorine Monitoring.....	34
6.2.5	Routine Maintenance	34
6.3	pH, ORP and Temperature Measurements.....	35
6.3.1	Installation	35
6.3.2	Routine Maintenance	36
6.3.3	Shut-down and Winterizing.....	37
6.3.4	Replacing Sensors.....	37
6.4	Turbidity Measurements	38
6.4.1	Installation	38
6.4.2	Relay Wiring and Use	40
6.4.3	First Time Set-up and General Operation.....	40
6.4.4	Routine Maintenance	41
6.4.5	Cleaning the Turbidity Sensor	41
6.4.6	Shut-down and Winterizing.....	42
6.4.7	Replacing Components.....	42
6.5	Conductivity Measurements	42
6.5.1	Installation	42
6.5.2	First Time Set-up and General Operation.....	43
6.5.3	Routine Maintenance	43
6.5.4	Cleaning the Conductivity Meter.....	43
6.5.5	Shut-down and Winterizing.....	43
6.5.6	Replacing Components.....	44
6.5.7	Replacing the Conductivity Meter	44
6.6	Flow Meter.....	44
6.6.1	Installation	44
6.6.2	Routine Maintenance and Troubleshooting.....	45
6.7	Communication Options	45
6.7.1	External 4 to 20mA Outputs.....	45
6.7.2	Internal 4 to 20mA Output.....	48
7	Appendix A: Relays and Closed-Loop Control.....	50
7.1	Connecting external equipment to the Relays.....	50
7.1.1	Wiring to Dosing Systems.....	50
7.1.2	Proportional Control Overview	51
7.1.3	Setting Proportional Factor	52
7.1.4	Setting Pump Period	52
7.1.5	Step By Step Proportional Settings	52
8	Appendix B: Technical Specifications	54

1.2 Overview of Chapters

This document is divided into functional sections according to the various steps involved in installing and operating the HydroGuard system.

Section 1: Manual Overview	Short Overview of manual layout and general precaution information
Section 2: Analyzer Overview	General description of how HydroGuard automatically monitors water quality
Section 3: Installation	Instructs how to install HydroGuard and how to integrate it with water quality systems
Section 4: First Time Set-up and Operation	Instructs how to configure, calibrate, and operate the HydroGuard system immediately after installation
Section 5: Routine Operation and Maintenance	Instructs how to respond to alarms and troubleshooting issues
Section 6: Measurement Options	Describes additional components that may be pre-installed or upgraded in the field
Appendix A: Relays and Closed-Loop Control	Describes HydroGuard's direct control components and operation
Appendix B: Technical Information	Table Summary of Technical data about the HG-702

2 Overview

The HydroGuard HG-702 Water Quality Analyzer continuously monitors chemical levels in a process water application. HydroGuard automates free chlorine, total chlorine, pH, ORP (Redox), temperature, turbidity, conductivity and/or flow rate, administering chemicals as required, according to the results of these tests (closed loop).

2.1 The HydroGuard Solution

Various methods have been developed over the years to monitor the concentration and balance of chemicals used in water treatment. The older manual methods of monitoring chemical balance are neither objective nor effective. HydroGuard measures free or total (and optionally both free and total) chlorine levels with a digital photometer, which has many advantages over other types of sensors. Digital photometer testing is completely objective. It is not dependent on lighting conditions or the operator's eyesight, and is far more accurate. It does not require frequent calibration and is compatible with all types of disinfectant systems. HydroGuard performs colorimetric testing in a closed reading cell. It is the only system that automatically and accurately measures free chlorine using small amounts of reagent.

Once installed and calibrated, HydroGuard is fully automatic. It will monitor and can control dosing systems directly or indirectly, releasing the proper quantity of chemicals based on frequent automatic measurements. HydroGuard is simple to use. Its straight-forward control panel and parameters menu make chemical balance control an easy task. All basic information can be viewed at a glance, and changing settings is as simple as scrolling through the menu and adjusting the current settings.

2.2 Measurements and Features

The HydroGuard 702 comes standard with chlorine measurement and can be configured to measure any combination of the following water quality parameters:

- Free Chlorine
- Total Chlorine
- Both Free Chlorine and Total Chlorine

Optional Measurements

- Turbidity
- Conductivity
- pH and Temperature
- ORP (Redox) and Temperature
- Flow Rate

Several communication options are also available:

- Internal 4 to 20 mA Outputs (up to 4 channels)
- External 4 to 20 mA Outputs (up to 8 channels + dry contact alarms)
- HydroSoft - Direct Connection
- Wireless Communication Package

2.2.1 Wireless Management Package*

An advanced and unique HydroGuard option is the cellular communication package which provides web-based monitoring of up to 5 analyzers. The cellular communicator accepts HydroGuard's alarms and readings and transmits them to a web-based application server. The information is easily accessible remotely through the Internet or mobile telephone.

* Optional Accessory – See supplemental information and manual

2.3 System Components

HydroGuard has two primary units: the analyzing unit and the control unit. The analyzing unit performs the actual measurements. It contains the following components:

Colorimetric Reading Cell - measures free or total (and optionally both free and total) chlorine levels in the water using DPD reagents and a closed-cell, digital photometer.

Flow Cell - contains the sensors, including the pH, Redox (ORP), and temperature sensors.

Reagent Bottles – contains the reagents used by the colorimeter to measure chlorine levels in the water.

Reagent Pumps and Solenoid Valve - accurately controls the flow of water and reagents into the colorimeter, making every measurement as accurate as possible.

The control units include all electronics, the user interface and the software that controls the measurements performed in the analyzing unit. It includes the following components:

I/O Module (Input/Output) – Power Supply to the analyzer and contains the dry-contact relays for direct control of external dosing systems.

Control Panel Module – Calculates the measurement results and determines the required chemical dosing to maintain an appropriate chemical balance in closed-loop systems, and

provides data to external communication devices such as 4 to 20mA Outputs or the wireless communication package.

Keyboard Panel - mounted on the cover of the control module, it functions as HydroGuard's user interface. The control panel displays current measurements and indicates alarms. All settings and adjustments are performed through the control panel.

Colorimeter Module - controls the colorimeter and associated components, such as the reagent pumps and solenoid valve. It calculates the accurate chlorine level.

pH, Redox, Temp Module* – receives the signal from the pH, Redox, and temperature probes.

Internal 4-20 Input Module* - Contains Connections for Turbidity, Conductivity meter, and 4-20 Flow Meter.

Internal 4 to 20 Output Module* – Provides up to 4, 4 to 20mA outputs for any measured variable.

External 4 to 20 Module* – Provides up to 8, 4 to 20mA outputs for any measured variable. Contains dry contacts for alarms not related to measured values including: low reagents, no reagents, no flow, etc.

*Optional Module

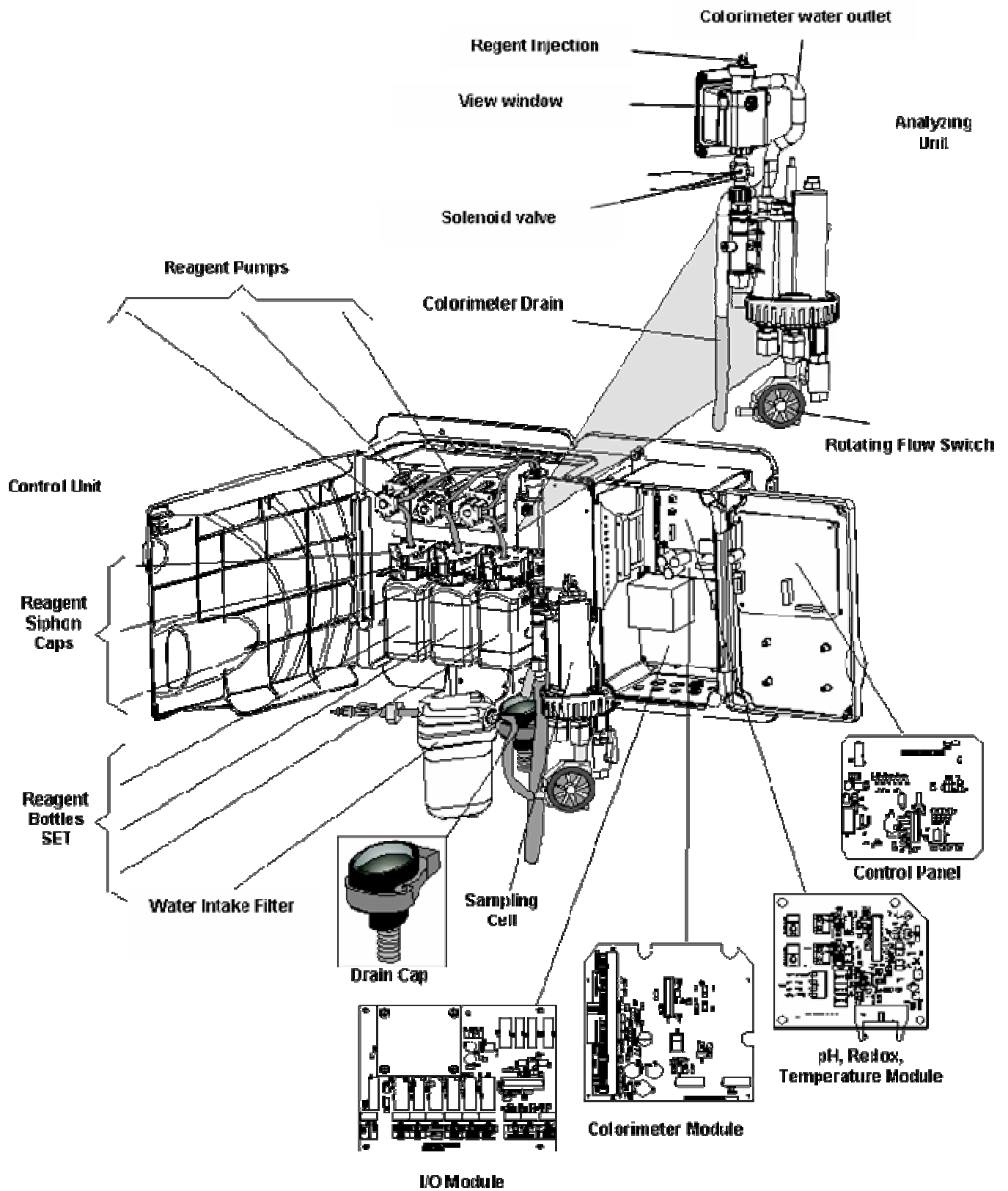

Figure 1: HydroGuard 702 Main Components

3 Installation

3.1 Selecting a Location

Take extra time in selecting a location since the installation location will determine the ease of the installation and future operation and maintenance. The location where HydroGuard is installed is dependent on various considerations:

Convenient Access - HydroGuard should be installed where it can easily be viewed and operated.

Dry Area – HydroGuard handles electricity and includes electronic circuitry that is susceptible to short-circuiting and/or corrosion when exposed to water or high ambient moisture levels.

Away from Chemicals - Many water treatment chemicals can be corrosive to HydroGuard's electronic circuitry. It is highly recommended that HydroGuard is not installed adjacent to the chemicals storage area or the dosing systems themselves.

Minimum Distance from Supply Pipe - The water sampling line that is connected to the main pipe, feeding the HydroGuard should be as short as possible. A long sample creates an unnecessary delay between supply, measurement, analysis, and chemical dosing.

Drainage – The location should easily allow the outlet of the colorimeter to gravity drain without creating an obstacle (i.e. no pipe across walkway). The flow cell may be pressurized to allow for return to the system under pressure.

Freezing Temperatures – The analyzer should be installed in a location that is not susceptible to freezing temperatures. The reagents will freeze, preventing accurate readings (even when thawed) and parts may be damaged due to expansion when ice forms.

3.2 Site Requirements and Installation

The HydroGuard assembly is wall mounted. It should be located on a wall where operators and service technicians can easily access it for normal operation and maintenance. It is also advisable to install it where the operators can easily view the readings and alarms. Finally, the complete unit with all connections weighs 18 lbs. (8 kg), so, it must be mounted securely onto a stable wall. The HydroGuard unit measures 26.3" x 13.1" (66.8 cm x 33.2 cm). The base of the complete HydroGuard assembly should be mounted at least 24" (60 cm) above the floor (preferably at eye level).

The HydroGuard unit and its mounting panel are not shipped with mounting screws or anchors. The installer must provide screws and anchors that can hold the weight of the HydroGuard unit, mounting panel, intake filter, and electrical outlets and junction boxes. The screws and anchors must be compatible with the wall where it will be installed.

3.2.1 Mechanical Installation

- 1) HydroGuard is shipped pre-mounted on a mounting panel, along with a water filter. The mounting panel includes four screw holes, one in each corner.
- 2) Determine the location of one hole on the HydroGuard unit or on the mounting panel.
- 3) Secure one corner of the HydroGuard unit or mounting panel to the wall.
- 4) Level the HydroGuard unit or mounting panel and mark the remaining three (3) screw holes.
- 5) Secure the remaining corners to the wall using 5/16" (8 mm) screws.

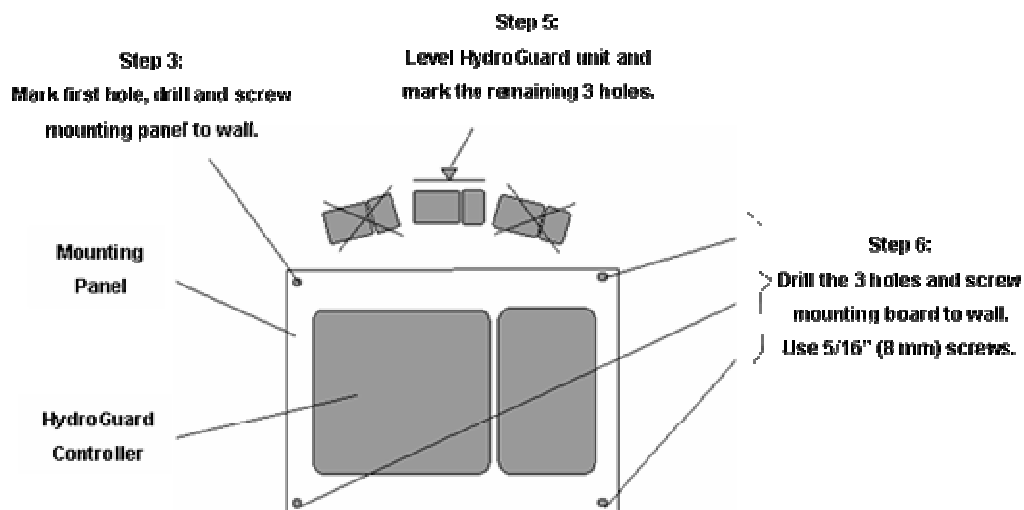

Figure 2: HydroGuard 702 Mounting Panel

3.3 Plumbing Requirements and Installation

3.3.1 Water Supply

HydroGuard requires a pressurized water supply to the flow cell, a zero pressure (gravity) water return from the colorimeter and a pressurized (or gravity) return from the flow cell. An isolating valve must be installed in the main line and the pipe (or tube) from the main pipe should be as short as possible, in order to minimize the delay time between the water being sampled and HydroGuard testing the water and adjusting dosing levels (see section 3.1). The inlet pressure should not exceed 36 psi (2.5 bar) and should be adjusted to 7 psi (0.5 bar) using a pressure regulator attached to the outlet of the pre-filter.

3.3.2 Drainage

Two drainage connections are required. A gravity drainage connection is required for the water coming from the colorimeter. A pressurized, vacuum, or gravity connection is required from the outlet of the flow cell. The length the colorimeter drain line should be as short as possible and must have a constant downward slope to prevent a backup of water. The flow cell may be pressurized up to 7 psi (0.5 bar). A drain cap is located on the colorimeter outlet to prevent the backup of water into the colorimeter if the drain line is blocked. A 1/2" MNPT fitting is supplied for the colorimeter drain connection and a 1/4" FNPT fitting is supplied for the flow cell drain connection.

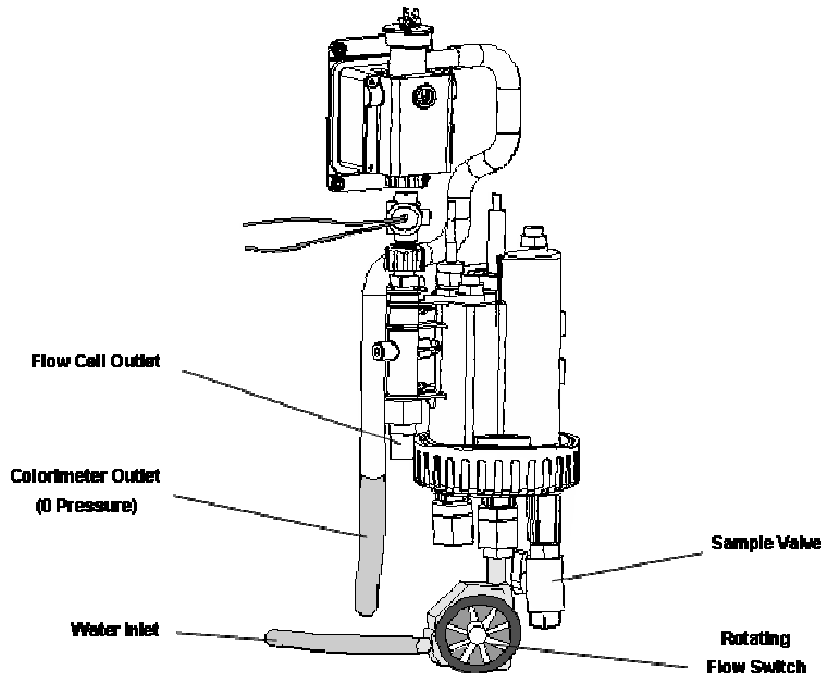

Figure 3: Flow cell and Colorimeter Inlet and Outlet

Note: The HydroGuard colorimeter drains water at zero (0) pressure. The drainage pipe should be as straight as possible and have a constant downward slope and should not have any bends where water flow can be restricted. If the colorimeter drains to a bucket or basin, the end of the drainage pipe should terminate above the bucket or basin rim.

3.4 Electrical Requirements and Installation

HydroGuard requires a 90-120 or 180-240 VAC, 50/60 Hz electrical power source on a separate 16A circuit in the plant room's electrical board. The main HydroGuard power supply should be connected to a non-dependent power supply, so that the unit remains powered constantly. The active relays should be connected to a dependent power supply (interlocked power supply)

3.4.1 Connecting the Main Electrical Power

The Main Power Supply may be connected to either 90-120 or 180-240VAC 50/60Hz. Switching between voltages is accomplished by changing two (2) jumpers located above the main power connection, to the left of the transformer. For 90-120VAC, a 1amp fuse should be use; for 180-240VAC, a 0.5amp fuse should be used. These changes must be completed prior to wiring.

Caution: Before making a connection to a power source, confirm that both jumpers are located on the correct voltage and that the appropriate fuse is in place.

- 1) Verify that the power switch or circuit breaker to the non-dependent power source is off.
- 2) Connect the line (live) wire to the I/O board connector marked Line.
- 3) Connect the neutral wire to the I/O board connector marked Neutral.
- 4) Connect the earth wire to the I/O Module connector marked Ground.
- 5) Continue with the other electrical connections.
- 6) Turn on electrical power only after all electrical connections have been completed.

For information on wiring and using the relays as dry contact or for control, see Appendix A: Relays and Closed-Loop Control.

3.4.2 Input Switches

Flow input switch terminal blocks on the I/O module allow for three input switches to be connected to the system as additional layers of security against accidental chemical additions when there is no flow. If a connection is expected but not detected at each input, the analyzer/controller will indicate an alarm and will close all relays (and open the alarm relay). Therefore, if a safety switch (flow, level, etc.) will not be installed, a fixed connection (jumper wire) is required to allow the controller to operate.

Two flow switches and one flow meter may be connected:

- Flow Switch (internal): Flow switch connected to flow cell of analyzer. Supports both 2 and 3 wire flow switches.
 - If a 2 wire switch is used, it should be connected to the “In” and “Gnd” connections. If a 3 wire switch is used, the “VCC” connection will also be used.
- External Flow Switch: Connection for external 2-wire flow switch. If an external switch is not connected, a jumper must be installed for the analyzer to operate properly.
- Flow Meter: Connection for 2 or 3 wire flow Meter. The analyzer will not look for the flow meter connection unless the option is turned ON in technician menu; therefore, no jumper is required if a meter is not installed.

Caution: Electrical connections in this section are ONLY recommendations. All electrical connections should comply with National Electrical code (NEC) and all local regulations.

4 First Time Operation and Calibration

4.1 Installing additional Sensors and Meters

Install all additional sensors and meters and connect to the HG-702 main system, following the supplemental manuals for each sensor or meter.

4.2 Installing Reagents

For Free Chlorine Only measurements, DPD1 reagent set will be used; for Total Chlorine Only measurements, DPD4 reagent set will be used. For both Free and Total Cl measurements, DPD1 and DPD3 reagent sets will be used.

The reagents should be installed according to the labels located behind the reagent holder. For systems order previously, please refer to the following installation:

For Free Cl Only:

1. Free Chlorine Indicator (DPD #1)
2. Free Chlorine Buffer (DPD #1)

For Total Cl Only:

1. Total Chlorine Indicator (DPD #4)
2. Total Chlorine Buffer (DPD #4)

For Free Cl + Total Cl:

1. Free Chlorine Indicator (DPD #1)
2. Free Chlorine Buffer (DPD #1)
3. Total Chlorine Indicator (DPD #3)

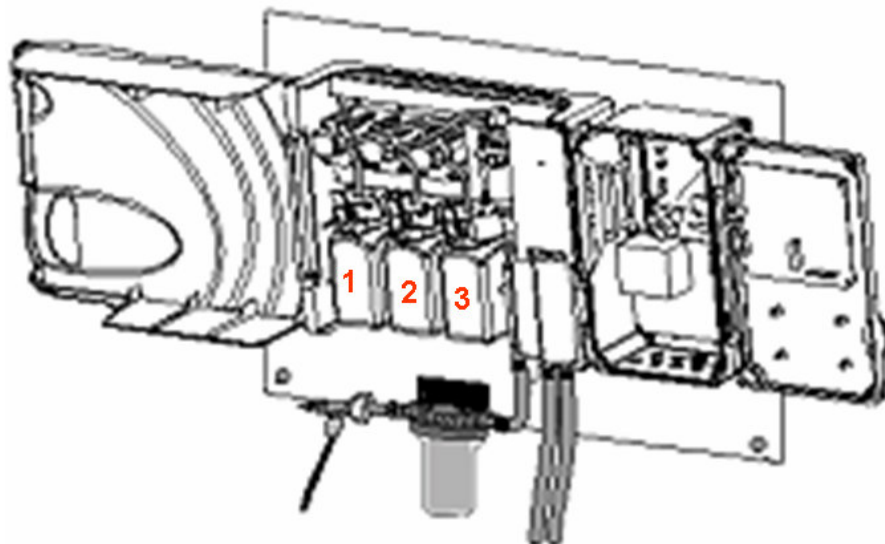

- 1) Open the HydroGuard Chlorine Indicator and Buffer kit.
 - a) The following items should be in the box:
 - i) 500 ml bottle of chlorine buffer with a white label.
 - ii) 500 ml bottle of chlorine indicator fluid with a blue label.
 - iii) Small bottle of chlorine indicator salt with a white label.
- 2) Remove the caps on both the indicator fluid and small indicator salt bottles.
- 3) Empty the entire contents of the indicator salt into the bottle of indicator fluid.
- 4) Place the cap on the bottle of chlorine indicator fluid and close tightly.
- 5) Turn the bottle upside-down slowly and carefully, so that no bubbles form in the fluid.
- 6) Repeat five (5) times until all the indicator salt is dissolved in the indicator fluid.

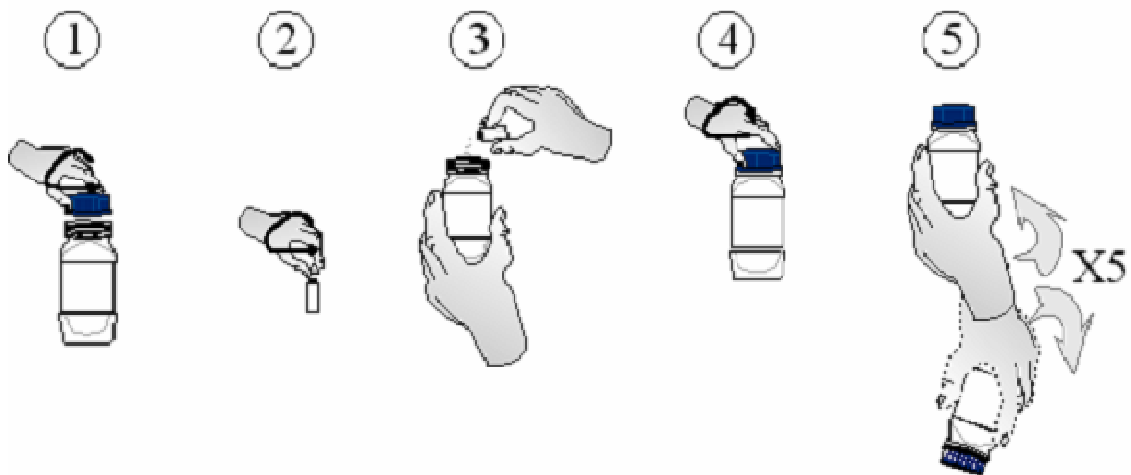

- 7) Place the reagent bottles in position:
- Remove the cap from the reagent bottles.
 - Place the opening of the reagent bottle below the bottle siphons.
 - Lift the bottle up until the opening reaches the bottle siphon cap.
 - Push the lever above the siphon cover away from you, and push the reagent bottle up.
 - Push the bottom of the bottle into position.

Caution

Do not refill the reagent bottles.
 Do not mix or add reagent from other bottles.
 Do not use any non-Blue I Water Technologies' reagents.

- 8) Prime the reagent pumps:
- Press Menu on the control panel keypad until the Reagent Pump menu appears.
 - Press OK
 - Enter password (123 is default) using the up or down arrows
 - Press OK (OFF will appear on top line)
 - Press OK again (OFF will appear on top and bottom lines)
 - Press UP to turn the reagent pumps ON
 - Press OK when the water flowing from the colorimeter has a red tint or reagent drops are being formed at the needle tips.
 - Press Escape twice (2x) to return to the main screen

Note: If outside of the range of 0.2 to 10 ppm, remove the colorimeter cap and confirm that reagents are being pumped.

4.3 First Time Menu Setup

This section describes how to configure the settings (set points, alarms, and calibrations) through the HydroGuard control panel.

Caution: HydroGuard's control board unit should not be opened except for initial installation and troubleshooting and should only be opened by a trained and approved technician.

4.3.1 HydroGuard Control Panel

The HydroGuard control panel is a simple, intuitive interface for monitoring and controlling water quality with the following components:

LCD Display	At the top of the control panel is an LCD display which shows all measured variables at top and all Alarms and Menus at bottom
Menu Button	Enters and scrolls through the menus
Esc	Moves one level back in the menu without making changes
OK	Enters setting change mode and accepts setting change
Up/Down Arrows	Changes value up or down

When an alarm is issued, the bottom row of the LCD displays the alarm.

Pressing the up and down arrows together will display the Langelier index for approximately five (5) seconds, and then returns to the previous display mode.

4.3.2 Menus

HydroGuard has two menu levels: Operator and Technician. The Operator menu includes settings that may be controlled by on-site operators. The Technician menu includes settings and calibrations that should be restricted to specially trained HydroGuard maintenance technicians. Each menu has a separate password. The technician level password may be used whenever a password is required, however the operator password will only be accepted in the operator menu.

Table 1 displays the operator menu functions and their description and Table 2 displays the menu functions with the minimum and maximum values for each.

Table 1: Operator Menu Functions and Descriptions

Menu #	Name	Description
1	Menu Relays	Manual activation of Relays
2	Reagent Pump	Manual activation of Reagent Pumps
3	CI Set Point1	Controls CI Relay 1 - On/Off or Proportional
4	CI Set Point2	Controls CI Relay 2 - On/Off only
5	CI Calibrated to	shows most recent calibration and sensor value at calibration to aid in troubleshooting
	CI Sensor was	
6	CI low alarm	Alarm when CI below this value
7	CI high alarm	Alarm when CI above this value
8	CI interval	time between CI measurements
9	pH set point	Controls pH Relay 3 - On/Off or Proportional
10	pH Calibrated to	shows most recent calibration and sensor value at calibration to aid in troubleshooting
	pH Sensor was	
11	pH low alarm	Alarm when pH below this value
12	pH high alarm	Alarm when pH above this value
13	ORP Set Point1	ORP set-point for emergency mode only
14	ORP Calibrated to	shows most recent calibration and sensor value at calibration to aid in troubleshooting
	ORP Sensor was	
15	ORP low alarm	Alarm when ORP below this value
16	ORP High alarm	Alarm when ORP above this value + Open CI relays 1+2
17	Temp Set Point	Controls Temperature Relay 6
18	Temp Calibrated to	shows most recent calibration and sensor value at calibration to aid in troubleshooting
	Temp Sensor was	
19	Temp Low Alarm	Alarm when Temp below this value
20	Temp High Alarm	Alarm when Temp above this value
21	Turbidity setpoint	Controls Turbidity Relay 4 - optional module
22	NTUI Calibrated to	shows most recent NTU low calibration and sensor value at calibration to aid in troubleshooting
	Sensor value was	
23	NTU _h Calibrated to	shows most recent NTU high calibration and sensor value at calibration to aid in troubleshooting
	Sensor value was	
24	Turb. High alarm	Alarm when Turbidity above this value - optional module
25	Alarm Delay	Time delay before Alarm Relay 5 closes
26	Flow low limit	Low flow limit for external flow meter
27	Flow K-factor	K-factor for external flow meter
28	Total Alkalinity	Manually entered for Langelier Index
29	Total Hardness	Manually entered for Langelier Index
30	TDS	Manually entered for Langelier Index
31	ORP Emergency Mode	Allows ORP mode to be used if CI measurement problem
32	Language	Allows choice of language
33	System Reset	Restarts controller - safer than turning off and on

Table 2: Operator Menu and Variable Limits

Menu #	Name	Min Value	Max Value	Default	Units
1	Menu Relays	OFF	ON	OFF	--
2	Reagent Pump	OFF	ON	OFF	--
3	Cl Set Point1	0	9.99	1.5	ppm
4	Cl Set Point2	0	9.99	0.5	ppm
5	Cl Calibrated to	0.1	9.99	n/a	ppm
	Cl Sensor was	0.1	9.99	n/a	ppm
6	Cl low alarm	0	9.99	0.5	ppm
7	Cl high alarm	0	10	2.00	ppm
8	Cl interval	2:00	10:00	2:00	min
9	pH set point	4.0	10.0	7.40	--
10	pH Calibrated to	4.0	10.0	n/a	--
	pH Sensor was	4.0	10.0	n/a	--
11	pH low alarm	4.0	10.0	6.9	--
12	pH high alarm	7.0	14.0	7.8	--
13	ORP Set Point1	0	1200	600	mV
14	ORP Calibrated to	0	1200	n/a	mV
	ORP Sensor was	0	1200	n/a	mV
15	ORP low alarm	0	1200	600	mV
16	ORP High alarm	0	1200	850	mV
17	Temp Set Point	1 / 34	49.9 / 121.9	22°C	°C / °F
18	Temp Calibrated to	1 / 34	49.9 / 121.9	n/a	°C / °F
	Temp Sensor was	1 / 34	49.9 / 121.9	n/a	°C / °F
19	Temp Low Alarm	1 / 34	49.9 / 121.9	18°C	°C / °F
20	Temp High Alarm	1 / 34	49.9 / 121.9	50°C	°C / °F
21	Turbidity setpoint	0	40	0.60	NTU
22	NTU Calibrated to	0	1	n/a	NTU
	Sensor value was	0	1	n/a	NTU
23	NTU Calibrated to	1.1	40	n/a	NTU
	Sensor value was	1.1	40	n/a	NTU
24	Turb. High alarm	0	99.99	99.99	NTU
25	Alarm Delay	0	10	0:30	min
26	Flow low limit	0	200 or 999	0 = off	m ³ /hr or GPM
27	Flow K-factor	0.01	655	0.01	--
28	Total Alkalinity	0	600	0	ppm
29	Total Hardness	0	600	0	ppm
30	TDS	0	5000	0	ppm
31	ORP Emergency Mode	OFF	ON	OFF	--
32	Language	Language Selection		English	--
33	System Reset	n/a	n/a	n/a	--

4.3.3 Configuring Settings in the Operator Menu

Each of the parameters in the operator menu is configured in the same way. The following procedure describes how to configure a typical setting:

- 1) Locate the desired parameter in the menu:
 - a) Press Menu until the desired parameter name appears in the LCD display.
- 2) Press OK. Enter Password 100 appears in the LCD display.
- 3) Enter the Operator password (or technician password; both are accepted)
- 4) Press the up arrow or down arrow until the password number is reached.

Note: Holding Menu when pressing up or down will advance the first digit. Holding up or down for an extended period of time will proceed through the numbers more quickly. The factory-set operator password is 123. The operator password can only be changed by entering the current operator or technician password (see Technician Menu Setup).

- 5) Press Enter to accept the password. The parameter name and current setting appear in the LCD display.
- 6) Press Enter, again. The LCD display shows the parameter and the current setting.
- 7) Enter the new parameter setting:
 - a) Press the up arrow or down arrow until the desired value is reached.
 - b) The second row of the menu display, below the value that is being changed, shows the current value.
- 8) Press Enter to save the new setting or Esc to abort without saving the new setting.

To change the settings of additional parameters, press Menu until the desired parameter appears in the LCD display and repeat steps 6-8 above to set the new parameter.

Note: The Menu button displays the next parameter in the list, so that the operator can check every parameter in the menu. There is no scroll-back option. To view or change a previous parameter in the menu, you must exit the menu by pressing Esc, and start the above procedure from the beginning.

4.4 Calibration

Parameters must be calibrated with measurements taken with external testing devices. Always use digital calibration devices, not the less accurate visual test kits. Alternatively, standard solutions may be used. Make sure the standard solution is not expired or contaminated prior to using. Follow the procedures below EXACTLY as instructed.

ALWAYS take water for calibration from the sampling valve, NOT from the process line directly. The analyzer should always be calibrated with water from the same source.

Note: Chlorine calibration is only required every 6 to 12 months in most cases. Minor deviations will exist between all testing equipment. These minor differences do not warrant the calibration of the colorimeter.

4.4.1 Chlorine Calibration

- 9) Open the water sampling valve. Let water flow while observing the colorimeter countdown timer in the LCD display.
- 10) Fill the sampling container when the countdown timer reaches zero (0).
- 11) Test the water sample for chlorine using a digital photometer.
- 12) Press Menu until "Cl Calibrated to" appears in the LCD display.

The top line will display “Cl Calibrated to” and a number. The number displayed is the last value someone entered for the calibration. The bottom line will display “Cl Sensor was” and a number. This number is the sensor reading without any calibration at the time of the last calibration. If there is a large discrepancy between these two numbers, the sensor was calibrated improperly or there is a problem with the analyzer. The value displayed normally on the main screen and the value the analyzer uses to determine dosing rates is the calibrated value.

Note: Chlorine calibration should always be performed within 25% of the set point. If current chlorine level is 25% above or below the set point, do not perform calibration until the chlorine level is closer to the set point.

- 13) Press OK.
- 14) Enter the password. Press the up arrow or down arrow until the password is reached.
- 15) Press OK.
- 16) Press OK again.

The display will now show “Calibrate Cl to” on the top line and “Sensor Reading” on the bottom line. The “Sensor Reading” is the current reading of the sensor with no calibration. The “Calibrate Cl to” value is the new value which you want to set.

- 17) Press the up arrow or down arrow until the value is the same as the value given by the digital photometer.

Note: The HydroGuard will not allow calibration above +/- 0.5ppm from the un-calibrated sensor reading. If the value given by the digital photometer is more than +/- 0.5ppm from the currently calibrated value, retest the water in the digital photometer. If the value is still more than 0.5ppm above or below the calibrated value, try testing the water with another device. If there is still a deviation of more than 0.5ppm between the new digital photometer, there may be a problem with the HydroGuard colorimeter, which cannot be corrected by calibration alone.

- 18) Press OK to save the new calibration or Esc to abort without saving.
- 19) Press Esc to return to the main display.

4.4.2 Calibrating other Sensors and Meters

Calibration of other sensors and meters is similar to the chlorine calibration and requires the use of a reliable external testing device or standard solution. See the supplemental manuals for each sensor or meter for specific information on calibration.

4.5 Technician Menu Setup

The Technician menu includes advanced parameter settings that are accessible separately from the Operator menu. Anyone can view the settings, but only someone with technician password can change. This has been done to allow only those who are qualified to change the advanced analyzer settings. These are also settings that should not require frequent changes after the initial installation and set-up.

Table 3: Technician Menu Functions and Descriptions

Menu #	Name	Description
51	Cl P factor	Proportional Factor for Cl Relay 1
52	Cl pump period	1 Pump cycle (on +off time) for Cl Relay 1
53	Cl pump freq	Cl pump max pulses/min, 0 for on/off pump
54	Cl Overfeed Time	Will open relay 1+2 if Cl feeding continuously for this time
55	Cl Averaging	Displays an average of the last 4 Cl readings
56	Cl < 0.1 Alarm	If Cl drops below this level, Alarm indicated and Opens Cl Relay 1+2
57	pH p factor	Proportional Factor for pH Relay 3
58	pH pump period	1 Pump cycle (on +off time) for pH Relay 3
59	pH pump freq	pH pump max pulses/min, 0 for on/off pump
60	pH Overfeed Time	Will open relay 3 if pH feeding continuously for this time
61	pH balance type	To Select if Acid or Base is being added to adjust pH
62	Flow Sensor	Will turn display of Flow rate on/off (only use if flow meter connected)
63	Flow Rate	Choose between metric and US units
64	Celsius/Farh	Choose between metric and US units
65	Temp Hysteresis	Value in degrees, below set-point which will close Temp Relay 6
66	Turbidity	Turns Turbidity Module ON/OFF (optional module)
67	NTU wiper interval	Interval for Turbidity Module Wiper to clean glass (optional module)
68	Minutes	Current Time for Data Logger
69	Hour	Current Time for Data Logger
70	Day	Current Time for Data Logger
71	Month	Current Time for Data Logger
72	Year	Current Time for Data Logger
73	Recording Interval	Time interval between readings stored on the on-board data logger
74	Tot Chlor	Turns Total Chlorine Measurement ON/OFF - Will ONLY operate in Free OR Total; must also change reagent set
75	View Free Cl	Displays measurement value on LCD
76	View pH	Displays measurement value on LCD
77	View ORP	Displays measurement value on LCD
78	View Conductivity	Displays measurement value on LCD
79	Address	Controller ID - used with external communication
80	Software Version	Current software version
81	Max Flow Range	Maximum Flow Rate (flow at 20mA) of 4-20mA flow meter
82	4-20mA Output Settings	Configures outputs for internal 4-20mA module
83	On Alarm go to	4-20 mA output during an alarm condition
84	Operator Password	Change operator password
85	Technical Password	Change technician password

Table 4: Technician Menu and Variable Limits

Menu #	Name	Min Value	Max Value	Default	Units
51	Cl P factor	0.1	50	0.1	--
52	Cl pump period	0.5	4	0:30	min
53	Cl pump freq	0 (0 = on/off pump)	120	0	max pulses/min
54	Cl Overfeed Time	0 (0 = off)	360	0	min
55	Cl Averaging	OFF	ON	ON	--
56	Cl < 0.1 Alarm	OFF	ON	ON	--
57	pH p factor	0.1	100	1.0	--
58	pH pump period	0.5	4	0:30	min
59	pH pump freq	0 (0 = on/off pump)	120	0	max pulses/min
60	pH Overfeed Time	0 (0 = off)	360	0	min
61	pH balance type	Acid	Base	Acid	--
62	Flow Sensor	OFF	ON	OFF	--
63	Flow Rate	m ³ /hr	GPM	m ³ /hr	--
64	Celsius/Farh	°C	°F	°C	--
65	Temp Hysteresis	0.1	1	0.1	°C or °F
66	Turbidity	OFF	ON	OFF	--
67	NTU wiper interval	1	60	2	min
68	Minutes	1	59	n/a	min
69	Hour	0	23	n/a	hour
70	Day	1	31	n/a	day
71	Month	1	12	n/a	month
72	Year	1	99	n/a	year
73	Recording Interval	1	240	0:03	min
74	Tot Chlor	OFF	ON	OFF	--
75	View Free Cl	OFF	ON	ON	--
76	View pH	OFF	ON	ON	--
77	View ORP	OFF	ON	ON	--
78	View Conductivity	OFF	ON	ON	--
79	Address	1	32	1	--
80	Software Version	n/a	n/a	n/a	--
81	Max Flow Range	0	200 / 999	200	m ³ /hr or GPM
82	4-20mA Output Settings	n/a	n/a	n/a	--
83	On Alarm go to	2	20	2	mA
84	Operator Password	1	999	123	--
85	Technical Password	1	999	456	--

4.5.1 Configuring Settings in the Technician Menu

Navigation within in the Technician Menu is identical to the operator menu.

- 1) To enter the Technician menu, press Menu to enter the operator menu and then the up arrow and down arrow together simultaneously until the menu display changes.
- 2) Locate the desired parameter in the menu:
 - a) Press Menu until the desired parameter name appears in the LCD display.
 - b) Press OK. Enter Password 100 appears in the LCD display.
- 3) Enter the Technician menu password:
 - a) Press the up arrow or down arrow until the password number is reached.
 - b) Press OK. The parameter name and current setting appear in the LCD display.

Note: Technician menu password is different from the Operator menu password. The default Technician menu password is 456 and if lost, can only be reset by replacing the chipset.

- 4) Continue changing the parameter setting, as described in the Operator menu.

4.6 Menu Feature Description

There are several features of the analyzer that are not immediately obvious from the menus.

Water Savings Mode: To minimize the amount of water passing through the colorimeter, the analyzer operates in a water savings mode. The solenoid valve will open for 15-20 seconds to obtain a new a fresh sample. The valve will close and the sample sequence will start. Once complete, the valve will remain open for an additional 20-30 seconds to completely flush the sample cell.

ORP Emergency mode: If a problem occurs with the colorimeter (unclean cell, stuck piston, communication error), or the customer runs out of reagents, the analyzer may be temporarily operated in ORP Emergency Mode. This mode must be started manually, by scrolling to the ORP Emergency Mode Menu, entering the password, and switching the mode to ON. If no colorimeter problem is present, the analyzer will not allow this mode to be entered. When in ORP Emergency mode, the ORP set point will be used to control Relay 1 (primary Cl relay). When the problem is corrected, the analyzer will automatically resume operation in normal mode. If not corrected after 3.5 days, the analyzer will close Relay 1.

Cl < 0.1 alarm option: Whenever the Cl measurement is < 0.1 ppm, the analyzer will disable relay 1 and relay 2. This alarm is provided as an extra level of safety against over chlorination due to bleaching of reagents. However, it complicates the start-up of the analyzer when the Cl is being maintained at low levels. Therefore, this alarm feature may be turned off. For cases when the Cl level is always expected to be above 0.5ppm, Blue I Water Technologies highly recommends that this alarm remain in use except for start-up.

Cl and pH Overfeed timers: To prevent continued operation of equipment when a problem occurs, these timers will disable the Cl or pH relays if the relay has been active for more than the selected time. An alarm will be issued and the analyzer will need to be reset in order to restart the relay operation. If "0" is entered, the feature is off.

Chlorine Averaging: This feature will only affect the displayed value; not the action of the analyzer. This feature is intended primarily to prevent operators from making changes due to minor, normal fluctuations in the measured chlorine level. There is an option to have the average of the last 4 readings displayed on the screen or simply the previous reading. The analyzer will always act based on the last reading regardless of this setting.

4.7 Calibration and Initial Operation Checklist

Before leaving the site, perform the procedure in this section and record the requested values.

Calibrate the following HydroGuard parameters and enter the information into the table below. If pH and ORP are reading slightly low, do not calibrate as they will continue to increase for the first 24-48 hours.

Date	Site	Technician's Name
Parameter	Analyzer Reading	External Device or Standard Value
Free Cl		
Total Cl		
pH		
Redox (ORP)		
Temperature		
Turbidity		
Conductivity		
Flow Rate		

5 Routine Operation and Maintenance

Once installed by a qualified technician, HydroGuard can begin monitoring and controlling water quality. HydroGuard is specifically designed for easy operation; however some periodic maintenance is still required. Basic guidelines are provided in Table 6; however the actual schedule may vary depending on the actual conditions and use.

Service Required	Expected Frequency
Replacing Reagents	1 to 2 months
Cleaning Pre-Filter	1 month (clean when visible dirt/oil)
Cl Calibration	6 months
Other Sensor Calibration	1 to 3 months
Replacing Reagent Pump Head and Tubes	12 months

- **Basic Operation:** involves setting the desired parameters and monitoring the system for alarms. When operating normally, HydroGuard demands very little operator involvement.
- **Calibration:** Sensor sensitivity and accuracy can degrade or drift over time. For this reason, HydroGuard settings must be periodically recalibrated and compared with measurements from other measuring devices, such as electronic photometers, pH sensors, and thermometers or compared to standard solutions like pH buffers or ORP standards.
- **Reagent Replacement:** HydroGuard uses a very small amount (approximately 0.03 ml) of chlorine reagents each time water is sampled. The two 500 ml bottles to last approximately 4 to 8 weeks depending on the measurement interval selected. A Low Reagents alarm is issued when either one of the reagent bottles approaches depletion and should be replaced. If the reagents are not replaced before the reagents are depleted, the testing and chlorine dosing will stop and a No Reagents alarm will be displayed, therefore it is important to replace reagents before this occurs.
- **Filter Cleaning:** The HydroGuard unit has a filter installed in its water supply pipe, which collects particles and impurities. It should be cleaned or replaced periodically, depending on water quality. The filter cover is clear allowing for a quick visual inspection to determine if cleaning is required.
- **Shut-down and Winterizing:** If the analyzer will not be operating for an extended period of time or in areas where temperatures drop below freezing, all water must be removed from the analyzer to prevent components from breaking and the probes must be removed and stored in a warm area and kept wet at all times.
- **Start-up and Preventive Maintenance:** A preventative inspection and cleaning of components should be completed whenever the analyzer is restarted after a long (> 2 weeks) downtime or at least annually if the analyzer is operating constantly. Likewise, the analyzer has several mechanical components that will wear-out over time. To prevent future problems, these components should be check and/or replaced periodically.
- **Troubleshooting:** Occasionally problems will occur with the analyzer readings or chemical dosing. These problems are most often simple to correct. The troubleshooting section provides an outline to follow to help correct the problems easily.

5.1 Monitoring HydroGuard Alarms

HydroGuard issues alarms when it detects chemical levels that are above or below the allowed range. Every alarm is automatically displayed in the LCD status display and logged in the data logger. Most deviations in chemical levels, however, are automatically corrected. Thus, the internal alarms do not immediately activate an external alarm. A delay mechanism prevents false alarms from minor deviations that were automatically corrected. The external alarm is only activated after an internal alarm has been continuously active for a certain period of time, as defined by the operator.

The Alarm Delay command in the Operator menu sets the number of seconds HydroGuard waits before closing Relay 5, the relay that operates the external alarm. Only one alarm is shown on the screen at a time based on importance and the order in which it should be fixed. For example, if the pH is high and the ORP is low, only the pH alarm will be indicated since lowering the pH will likely also correct the low ORP. All of the alarms are presented in Table 5 along with a description and resulting action of the analyzer/controller.

Table 5: Alarm Description and Result

Alarm #	Alarm	Description	Result
A1	No flow	Flow switch in flow cell is off	No chemical dosing
A2	Low flow	external flow meter below minimum flow	No chemical dosing
A3	Check CLRMTR connect.	Communication error between colorimeter and colorimeter board	no chlorine dosing - optional ORP emergency mode
A4	No reagents	Reagents are empty	no chlorine dosing - optional ORP emergency mode
A5	Stuck piston	Piston is not moving properly	no chlorine dosing - optional ORP emergency mode
A6	Unclean cell	glass in colorimeter is dirty	no chlorine dosing - optional ORP emergency mode
A7	Replace light	LED in colorimeter is not working	no chlorine dosing - optional ORP emergency mode
A8	Low reagents	Reagents are below 20%	Blue LED will flash - Message only
A9	Chlorine < 0.1	Chlorine unusually low	no chlorine dosing
A10	High ORP	ORP above high limit	no chlorine dosing
A11	Low chlorine	Cl below low limit	--
A12	High chlorine	Cl above high limit	--
A13	Low pH	pH below low limit	--
A14	High pH	pH above high limit	--
A15	Low ORP	ORP below low limit	--
A16	High NTU	Turbidity above high limit	--
A17	EXTERNAL OFF	external flow switch is off	No chemical dosing
A18	Total Cl high	Total Cl above high limit	--
A19	Combine Cl high	Combined Cl above high limit	--
A20	Replace DPD3	DPD3 low	Total Cl testing stops
A21	Temp. low alarm	Temperature below low limit	--
A22	Temp. high alarm	Temperature above high limit	--
A23	Cl overfeed time	Cl dosing on for longer than max time	Cl dosing stops until reset
A24	pH overfeed time	pH dosing on for longer than max time	pH dosing stops until reset
--	No Emergency	No problem to allow ORP emergency mode	--

* No dosing only affects the relay operation. Alarm relay will close and all other relays will open.

5.2 Replacing Reagents

HydroGuard issues a LOW REAGENTS message when the float at the end of one of the reagent siphons detects that one or both of the reagents is approaching depletion. After this time, HydroGuard will count down (internally) until the reagents are expected to be completely depleted and the Cl analysis will stop and the analyzer will alarm. The blue LED lights in the flow cell will flash continuously until the reagents are replaced or they are depleted, resulting in a NO REAGENTS alarm and an opening of the chlorine relays, preventing any additional chlorine from being added. Prior to receiving the NO REAGENTS alarm, replace the reagents as described in Section 4.2.

Reminder: Once mixed (salt into the solution) the reagents have a shelf-life of 2 months, and will lose accuracy if used beyond this time limit.

5.3 Cleaning the Filter

The HydroGuard unit is sent to the site mounted on a mounting panel. Several other units are mounted on the panel, alongside the analyzer including a water filter, which filters out sand, rust, coarse debris, oil, and other impurities in the sampled water. These impurities may clog the HydroGuard's internal pipes, contaminate the sensors, or dirty the analyzing cell, reducing its accuracy.

This filter must be cleaned regularly as it becomes clogged with debris and impurities. The frequency at which the filter requires cleaning depends entirely on how much debris is in the water. The following procedure describes how to remove, clean, inspect, and if necessary, replace HydroGuard's water filter:

- 1) Locate the water filter, mounted below the HydroGuard unit, and the valve that is located on the water supply pipe.
- 2) Turn off water supply to the filter and remove the filter.
- 3) Remove any loose debris with your fingers.
- 4) Wash the filter under running water.
- 5) Inspect the filter and replace if any part of the filter fabric is torn.
- 6) Return the filter into place making sure that the gaskets and o-ring are in place.
- 7) Open the water supply valve.
- 8) Press the air relief valve to remove the air from the filter.
- 9) Confirm that the water is flowing and the filter is properly sealed.

5.4 Shut-Down and Winterizing

The HydroGuard analyzer is designed to keep the probes submerged even if there is no flow to the analyzer. However, if the analyzer is going to be offline for an extended period of time and/or exposed to freezing temperatures, it must be winterized to prevent damage to the analyzer and the probes.

- 1) Store all probes following directions in the supplemental manuals for each sensor.
- 2) Drain the flow cell completely by opening the sampling valve on the bottom. Leave the valve in the open position to allow air to completely dry the cell.
- 3) Remove the reagent bottles and flush each pump tube by inserting the pump tube in a container of fresh water and turning the reagent pumps ON for at least 90 seconds.
- 4) Remove the pump tubes from the water containers and turn the pumps ON for an additional 90 seconds to remove any water.
- 5) With the solenoid valve in the open position, turn off the power to the analyzer. If the solenoid is in the close position, the unions at the top and bottom of the solenoid should be loosened to allow the colorimeter and solenoid to completely drain.
- 6) Check the security of the analyzer doors to ensure a weatherproof seal.

5.5 Start-up and Preventive Maintenance

After the analyzer (or flow) has been off for a long period of time (> 2 weeks), a few simple checks should be done during the initial start-up. Several components may need to be cleaned and some mechanical parts may be replaced as preventative maintenance.

- 1) Remove the colorimeter cap and clean the quartz glass using a cotton swab.
- 2) Remove the solenoid and check the tip for corrosion (this may occur if shut down improperly) and check the stop for deterioration or signs of wear. The corrosion can usually be cleaned away and the solenoid will continue to work properly. After start-up, confirm that the water is completely stopped when the solenoid shuts. If not shutting properly, it must be cleaned or replaced.
- 3) Inspect the pump tubes for cracks or signs of significant wear and replace if necessary.
- 4) Install new reagents and prime the tubes.
- 5) Inspect the needles (in the colorimeter cap) to ensure that droplets are forming and falling properly. Replace if necessary.
- 6) Replace all additional sensors and meters, close the sampling valve and turn on flow immediately to re-wet any probes.
- 7) Recalibrate the analyzer.

Note: ORP and pH probes will likely require 24-48 hours to re-stabilize and will require re-calibration at this time.

5.5.1 Replacing Reagent Pump Head and Tubes

If the reagent pump head and/or tubes are cracked, appear significantly worn, or are no longer functioning properly, they should be replaced to ensure consistent operation and control.

- 1) Turn off the power to the HydroGuard analyzer.
- 2) Remove the tubes from pump head and the needles in the colorimeter cap by holding the top of each needle and pulling the tube gently
- 3) Remove the tubes from the reagent bottles and wipe off any excess reagent (the DPD will stain so be careful)
- 4) Unscrew the two (2) screws on the face of the pump head. Save the screws.
- 5) Remove the pump head by pulling gently and sliding the pump head off of the motor assembly
- 6) Slide the new pump head onto the motor assembly ensuring that the slot in the pump head matches the notch in the motor shaft. DO NOT force the pump head onto the motor assembly; it should easily slide into place.
- 7) Rotate the pump head and slide the alignment pins into motor assembly
- 8) Replace the two (2) screws to reattach the pump head.
- 9) Attach the new pump tubes by pressing the tubes onto the connectors on the end of the pump head.
- 10) Insert the pump tube leading to the bottom of the pump head into the appropriate reagent bottle
- 11) Attach the pump tube from the top of the pump head to the needle on the colorimeter cap by holding the needle and gently pressing the tube onto the connector.

5.6 Troubleshooting

The following procedures instruct how to locate, evaluate, and fix a problem when HydroGuard issues an alarm or indicates suspect chemical levels. Current and more detailed

troubleshooting tables are available for download under the customer support tab at <http://www.blueitechnologies.com>.

Alarm	#	Description	Symptom	Solution / Suggestion
No Flow	A1	Not enough water reach the controller. Stop all chemical dosing (all relays are open)	No chlorine measurements. No dosing	Increase flow and check flow switch wire connection on board. Check that the switch is not stuck.
Low Flow	A2	Water flow rate in main circulation pipe is lower than the flow limit. Stop all chemical dosing (all relays are open)	No dosing	Check the circulation pipes, not controller problem.
Check Colorimeter Connect	A3	No communication with the colorimeter	No Cl measurements	Check wiring Between colorimeter sensor and colorimeter board. Change colorimeter sensor case of continuing problem.
No Reagents	A4	Reagents are empty.	No reading	Check reagent level change bottle if needed. Make sure the sensor is not stack.
Stuck Piston	A5	Piston is not moving properly within the colorimeter.	No chlorine measurements. No chlorine dosing	Wait for the 2nd measurement and check visually. Clean the colorimeter assembly. Make sure the colorimeter connection is well connected to the "mixer" on control panel. OR not enough flow to colorimeter. Increase flow to analyzer.
Unclean Cell	A6	Impurities have accumulated in the colorimeter analyzing cell.	No chlorine measurements. No chlorine dosing	Clean tube with a cotton swab OR not enough flow to colorimeter. Increase flow to analyzer.
Replace Light	A7	The LED light in the colorimeter is not working. Insufficient connection on board	No chlorine measurements. No chlorine dosing	can resolder LED connection. Change colorimeter assembly
Low Reagents	A8	Starts when reagent level reaches 20%, and notifies how many days are left until the reagents are depleted.	Blue LED will flash completely ON then completely OFF	Message - NOT an error. Info indicating replacing is soon needed.
High ORP	A10	Redox (ORP) is above alarm level.	No Chlorine dosing. As safety against overchlorination	Compare to manual reading and recalibrate if necessary. Check unstable reading, due to poor grounding. Increase high/low ORP level if operation is normal. Replace probe if needed.
Low ORP	A15	Redox (ORP) is below alarm level.	Message Only	
Low Chlorine	A11	Free Chlorine level is below alarm level.	Message Only	Compare to manual reading! Check reagent flow from bottle to colorimeter. Check/clean solenoid valve (including spring). Check correct water flow. Verify piston movement ("mixing"). Check that dosing systems are operating properly.
High Chlorine	A12	Free Chlorine level is above alarm level.	Message Only	
Total CL high	A18	Total Chlorine level is above alarm level.	Message Only	
Low pH	A13	Acid/base level is below alarm level.	Message Only	Compare to manual reading and recalibrate if necessary. Check unstable reading, due to poor grounding. Increase high/low pH level if operation is normal. Replace probe
High pH	A14	Acid/base level is above alarm level	Message Only	
High NTU	A16	NTU level is above alarm level.	Message Only	Check constant reading. Compare to manual reading. Check wiper movement. Clean sensor window. Change if necessary.
External Off alarm	A17	Connections External flow Switch indicating no flow. Stop all chemical dosing (all relays are open)	Message Only	Make connection on I/O board with flow sensor on connections 5 + 6 or with jumper wire to complete circuit. Not recommended to operate with jumper only.
Combine CL high	A19	Combine chlorine level is above alarm level.	Message Only	--
Replace DPD3	A20		No reagent in The right bottle out of the three.	Replace Total Chlorine reagent.
Temp Low	A21	Temp level is below alarm level.	Message Only	--
Temp High	A22	Temp level is above alarm level	Message Only	
Cl pump Overfeed time	A23	Chlorine relay has been active for more than a pre-determined time limit and has shut off for safety reasons.	No Chlorine Dosing.	Confirm proper operation of dosing systems and perform a system reset
Chlorine < 0.1		Chlorine level is below 0.1 PPM.	No Chlorine Dosing	Compare to manual reading. If normal operation will be around 0.1 ppm range, disable alarm.
pH pump Overtime		pH relay has been active for more than a pre-determined time limit and has shut off for safety reasons.	No pH Dosing	Confirm proper operation of dosing systems and perform a system reset
ORP Emergency Mode		Problem with Colorimeter Reading. ORP is now controlling chlorine until problem is resolved (up to 3.5 days only).	Should use with care. This method as disadvantages that will not reflect same results as normal operation.	Function may be enabled, after no solution for alarms A3/4/5/6/7.

Problem / Symptoms	Potential Cause	Solution / Suggestion
Chlorine Measurement is Zero or Low	Reagent Pumps not Primed or broken	Prime for 90 seconds - confirm pumps work properly and droplets form and drop from each needle
	Chlorine too high (> 10ppm) and is bleaching reagents	Dilute and test manually -- controller will operate fine once back in normal level
	Solenoid not shutting completely	confirm that water stops flowing when reading starts (timer gets to zero). Unscrew solenoid and clean the tip -- check filter for holes.
	Using wrong or not original reagents or reagents have passed expiration date	make sure reagent are in good conditions, replace if needed
	Needles Blocked/Damaged	Turn reagents pumps ON and confirm that droplets forming as expected
	Valve malfunctioning.	Check/Clean valve and spring. Add grease. Replace Valve if necessary.
	Needle is cracked or tube split at needle	Needle will be black on outside -- DPD occasional does not drop properly b/c not flowing through needle
Chlorine Measurement Inconsistent	Cl averaging on	Check if Cl averaging on in Tech menu -- turn off it not wanted
	Calibrated at wrong level	Enter calibration -- enter password and press enter to accept reading from colorimeter
	Valve malfunctioning.	Check/Clean valve and spring. Add grease. Replace Valve if necessary.
	Needs Calibration (near set point)	If +/- 25% of set point, re-calibrate

5.7 Replacing Components

The following procedures describe how to replace certain HydroGuard components.

Caution: The following procedures should only be performed by properly qualified and trained HydroGuard analyzer technicians.

Warning: Disconnect all power supplies to the HydroGuard analyzer before opening the control unit door. Replacing any parts of HydroGuard without the expressed written authorization of Blue I Water Technologies Ltd. or the qualified representative who supplied the product may void the warranty.

Blue I Water Technologies Ltd. takes no responsibility, written or implied, for installation or maintenance of HydroGuard that is not performed by a properly trained and certified HydroGuard technician.

5.7.1 Replacing Flow Switch

- 1) Turn off the inlet and outlet water to the flow cell and the power to the analyzer.
- 2) Open the doors of both the analyzing module and the control module.
- 3) Locate the flow switch attached to the flow cell.
- 4) Disconnect the flow switch wires from the I/O module.
- 5) Remove the inlet connection to the old flow switch.
- 6) Remove the flow switch from the flow cell.
- 7) Pull the flow switch wires gently to completely remove from the analyzer
- 8) Insert the new flow switch on the flow cell
- 9) Insert the inlet connection on the flow switch
- 10) Route the flow switch wires back to the connection on the I/O module and connect the wires to the input switch terminal block.
- 11) Close the analyzer doors and turn on the water and power and ensure proper operation.

5.7.2 Replacing Reagent Siphons

- 1) Turn the power off to the analyzer.
- 2) Disconnect the two (2) red wires from the reagent level connector on the colorimetric module.
- 3) Remove the four (4) mounting screws.
- 4) Install the new reagent siphons.
- 5) Attach the four (4) mounting screws
- 6) Connect the two (2) red wires to the colorimetric module.

5.7.3 Replacing the reagent level sensor

- 1) Turn the power off to the analyzer.
- 2) Disconnect the two (2) red wires from the reagent level connector on the colorimetric module.
- 3) Unscrew the old sensor by hand and pull out the sensor along with its 2 red wires.
- 4) Install the new sensor by first pushing the 2 red wires into the sensor tube.
- 5) Screw in the sensor by hand.
- 6) Reconnect the 2 red wires to the colorimetric module.

5.7.4 Replacing Reagent Pumps

- 1) Turn the power off to the analyzer.
- 2) Disconnect both pipes from the reagent pump.
- 3) Remove the four (4) mounting screws.

- 4) Disconnect the Red and Blue wires from the Pumps connector on the colorimetric module.
- 5) Install the new pump and reconnect (in this order): the pipes, the 4 screws and the wires to the colorimeter module.
- 6) Turn the reagent pumps on until reagents are injected into the colorimeter cell (approximately 90 Sec.).

Note: If only the motor is to be replaced, the pump head will need to be removed and reattached. See Replacing Reagent Pump Head and Tubes 5.5.1.

5.7.5 Replacing Colorimeter

The HydroGuard water quality analyzer's colorimeter is a self-contained chlorine analyzing cell to determine the chlorine concentration in the water.

Follow the procedure below to replace the colorimeter.

- 1) Turn off the water inlet and outlet from the flow cell and turn off the analyzer power.
- 2) Open the doors of both the analyzing module and the control module.
- 3) Locate the colorimetric cell unit in the analyzing sets.
- 4) Disconnect the existing Colorimeter:
 - a) Remove the top cap from the colorimetric unit.
 - i) Make sure not to touch the reagent injection needles in the cap.
 - b) Disconnect the outlet tube from the colorimetric unit.
 - c) Unscrew the union between the solenoid valve and the Colorimeter.
 - d) Unscrew the four (4) mounting screws that hold the Colorimeter to the HydroGuard housing.
- 5) Open the control module door.
- 6) Trace the wires from the Colorimeter to the colorimeter control module connector. A total of four wire pairs (2x4) are connected to the control module (4 connected to the "MIXER" terminal block and 4 to the "SENSOR" terminal block).
- 7) Disconnect the Colorimeter's wires from the Colorimeter module.
- 8) Connect a new Colorimeter unit:
 - a) Hand tighten the union between Colorimeter and the solenoid valve until the Colorimeter is tightly connected to the valve. Check that the O-ring is still in place.
 - b) Screw the Colorimeter to the HydroGuard analyzing module housing with the four mounting screws.
 - c) Place the top cap on the Colorimeter unit.
- 9) Re-connect the outlet tube to the Colorimeter.
- 10) Pass the wires from the new colorimeter through the gasket into the control module.
- 11) Connect the wires to the "MIXER" and "SENSOR" terminal blocks as indicated on the colorimeter module.
- 12) Recheck all connections.
- 13) Close the HydroGuard analyzing module door.
- 14) Turn on the power and restore flow to the flow cell.
- 15) Confirm that the colorimeter is properly operating.

5.7.6 Replacing Colorimeter Solenoid Valve

- 1) Turn the water inlet and outlet to the flow cell and turn off the analyzer power.
- 2) Release the top union connecting the solenoid valve to the Colorimeter module.
- 3) Detach the cable from the solenoid valve.
- 4) Unscrew the solenoid valve intake tube.
- 5) Unscrew and disconnect the sampled water supply pipe from the solenoid valve intake pipe, at the bottom of the solenoid valve.
- 6) Disconnect the valve from the unions above and below.
- 7) Connect the new solenoid valve.
 - a) Connect the bottom of the new valve to the intake pipe.
 - b) Insert an o-ring into the slot at the bottom of the intake pipe, and turn until the intake tube is firmly connected to the new valve.

- c) Connect the top union to the valve and to the bottom of the Colorimeter unit and tighten.
- 8) Connect the solenoid valve cable to the Colorimeter module.

5.7.7 Replacing Control Panel Module (electronics card)

Disconnect the power supply to the unit before opening the control unit.

- 1) Disconnect the flat cable plug from the card.
- 2) Unscrew the four (4) mounting screws.
- 3) Put in the new card and tighten the 4 mounting screws.
- 4) Connect the flat cable plug to the card.

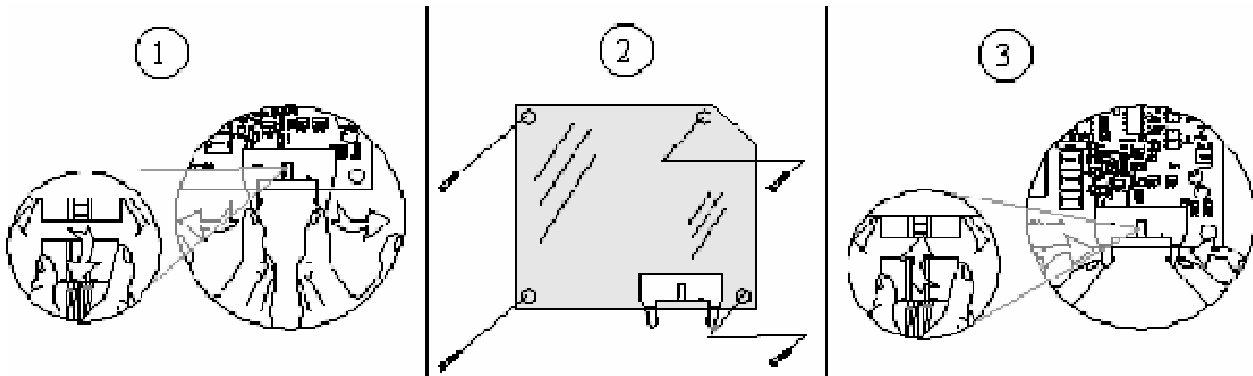

Figure 4: Replacing all types of electronic modules (cards)

5.7.8 Replacing I/O Module

Disconnect the power supply to the unit before opening the control unit.

- 1) Disconnect the flat cable plug from the card.
- 2) Unscrew the four (4) mounting screws.
- 3) Put in the new card and tighten the 4 mounting screws.
- 4) Connect the flat cable plug to the card.

5.7.9 Replacing Colorimetric Module

Disconnect the power supply to the unit before opening the control unit. If pH, ORP, and/or Temperature is being measured, first remove the pH, Redox and Temperature card.

- 1) Disconnect the flat cable plug from the colorimetric card.
- 2) Unscrew the four (4) mounting screws.
- 3) Put in the new colorimetric card and tighten the 4 mounting screws.
- 4) Connect the flat cable plug to the colorimetric card.

5.7.10 Module Software Update

Each electronic module (card) has a microcontroller chip (IC) with its own unique software. Whenever a module's software is updated, its chip must be replaced by a new version with the new software*.

- 1) Turn OFF the power to HydroGuard.
- 2) Locate the chip that needs to be replaced
- 3) Remove the chip carefully by prying up each end a little at a time with a thin screwdriver.
- 4) Install the new chip in the same location. Please note in the figure that the chip and the board each have a directional mark. The chip must be positioned so that these directional marks are aligned.

* The control panel has no IC, it is necessary to replace the module (electronics card).

Warning: Installing the chip in the wrong direction will damage the system and can create an electrical fire hazard.

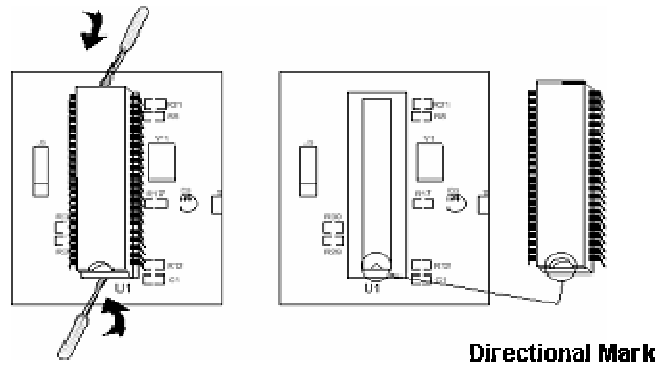

Figure 5: installing new chipset

6 Additional Measurements and Features

6.1 Additional Measurements

The following additional measurements may be added to the HG-702:

- Free + Total Chlorine monitoring (instead of just free or total)
- Turbidity
- Conductivity
- Flow Rate
- pH
- Redox(ORP)
- Temperature

6.2 Free + Total Chlorine Measurements

6.2.1 Installation

The Free Cl + Total Cl measurements is an optional feature that is supplied complete from the factory. However, in addition to the standard free chlorine set-up, some additional steps are required.

6.2.2 Installing DPD3 Reagent

The DPD-3 reagent bottle is installed the same as the DPD 1 and Buffer solution bottles and will be in a 500 ml bottle labeled as DPD-3.

- 1) Place the reagent bottle in position:
 - a. Remove the cap from the reagent bottles.
 - b. Place the opening of the reagent bottle below the bottle siphon on the right.
 - c. Lift the bottle up until the opening reaches the bottle siphon cap.
 - d. Push the lever above the siphon cover away from you, and push the reagent bottle up.
 - e. Push the bottom of the bottle into position
- 2) Prime the reagent pump for ninety (90) seconds until the reagent drops visible through the DPD 3 needles
 - a. turn reagent pumps on from operator menu

6.2.3 Additional Menus and First Time Set-up

In order to operate the free and total chlorine measurements, a few additional menus are required. The menus and their descriptions are listed below. The settings in these menus will need to be configured before operation. The tables below outline the menus specific to Total Chlorine monitoring in the operator and technician menu.

Table 6: Additional Menus in the Operator Menu

Name	Description
TC High Alarm	Alarm when the Total Chlorine is above this value
CC High Alarm	Alarm when the Combined Chlorine is above this value

Table 7: Additional Menus in the Technician Menu

Name	Description
Tot Chlor	Turns the total chlorine monitoring and display ON or OFF
Chlor Ratio	The ratio of Free Chlorine measurements to Total Chlorine Measurements

6.2.4 Activate Total Chlorine Monitoring

- 1) Enter the Operator Menu
- 2) Set the TC High Alarm Level
- 3) Set the CC High Alarm Level
- 4) Enter the Technician Menu (by pressing up and down together)
- 5) Press Menu until " Total Chlor ON/OFF" appears
- 6) Change to "ON" (the default is - OFF)
- 7) Press Menu until "Chlor Ratio" appears
- 8) Select the ratio of total chlorine measurements

The frequency of total chlorine testing will be based on the chlorine interval and the chlor ratio. If the Chlor Ratio is 1, the total chlorine will be tested every cycle. If Chlor Ratio is greater than 1, the Total chlorine will be tested every few cycles. For example, if the Chlor Ratio is 5, the total chlorine will be tested after every 5th Free chlorine test.

- 9) Perform a system reset to start operating in TC mode.
- 10) Locate the LCD displays in the HydroGuard control panel. A number should appear in the display (TCI - 0.00) and will update after the first total chlorine test.

6.2.5 Routine Maintenance

Reagent Replacement

Reagent replacement should be done after the message of "Replace DPD3" appears on the LCD. Refer to Installing DPD3 Reagent Section 6.2.2 for information on reagent replacement.

Calibration

Calibration of the free chlorine will automatically update/calibrate the total chlorine.

6.3 pH, ORP and Temperature Measurements

6.3.1 Installation

If the HydroGuard system was ordered with these components some steps in this process will have been completed in the factory and may be skipped.

Required Components

- pH, ORP, Temp Module (electronics card)
- 150 mm flat cable
- pH probe
- ORP probe
- Temperature probe

Note: the system may be operated with only pH or only ORP but must always have the temperature probe as this provides additional grounding to ensure reliable pH and ORP measurements.

The following procedure describes how to install the Redox (ORP) and pH sensors in the HydroGuard unit. The installation of all the sensors in the flow cell is similar, expect for the connecting wires.

Caution: Make sure the pH and Redox sensors have plastic or rubber plugs covering their ends. Use another sensor if the plug of any sensor is missing or has fallen off.

Make sure to connect the appropriate wire to the appropriate sensors. Labels are located on the wires near the probe connection and on the connection on the pH, Redox, Temp Module.

- 1) Turn off all power and water supplies to the analyzer
- 2) Install the pH, ORP, Temp module (electronics card) in the control module on the top left (above the colorimeter module, if present) using the 4 supplied screws.
- 3) Connect the flat cable to the pH, ORP, temp module to an open connector on the I/O module
- 4) Install the temperature probe
 - a. Thread the 3/8" compression connector into the back of the flow cell.
 - b. Place the probe into the connector until and hand tighten the connector.
 - c. Route the temperature probe wires into the electronics box and connect to the pH, ORP, Temp module following the color codes listed on the module.
- 5) Install the pH and/or ORP probes
 - a. Remove the sensor from its packing box and remove the plastic cover or plug from the end of the sensor and drain the solution from the tube. Keep the plastic cover in a safe place for winterizing or storage of probes.
 - b. Hold the sensor by its connector, with the glass tube pointing down.
 - c. Insert the sensor into 1/2" connector on the top of the transparent flow cell and thread in securely. DO NOT OVERTIGHTEN.
 - d. Route the pH and/or ORP cables to the electronics box and connect to the pH, ORP, temp module.
 - e. Connect each cable to the appropriate sensor.
- 6) Repeat step 5 for additional sensor. If only 1 sensor is installed:
 - a. install a jumper between the inputs for the missing probe
 - b. In the menu, set the low and high alarm limits at the minimum and maximum values respectively to prevent a false alarm for a measurement that is not connected.
- 7) Switch the HydroGuard ON, verify that pH and or ORP readings appears on the display. In some analyzers, this may need to be turned on in the technical menu.
- 8) Observe the pH and ORP (Redox) levels and wait several minutes until both readings stabilize.

- a) If either one or both indicators do not display a proper reading or are not stable confirm proper installation and then see Troubleshooting.

6.3.2 Routine Maintenance

Calibration

pH Calibration

pH is calibrated using an Phenol Red or Buffer 7 solution.

- 1) Shut off the water inlet and outlet from the flow cell
- 2) Remove the pH sensor and temperature probe from the flow cell.
- 3) Wipe sensor probe with a dry cloth and submerge it and the (PT-100) temperature probe into a cup with the Phenol Red or Buffer 7 solution and wait for the reading to stabilize.

Note: The reading will not stabilize if the temperature probe is not also in the buffer solution

- 4) Press Menu until pH Calibrated to appears in the LCD display.
- 5) Press OK.
- 6) Enter the password. Press the up arrow or down arrow until the password is reached.
- 7) Press OK.
- 8) Press OK again.
- 9) Press the up arrow or down arrow until the value is the same as the value printed on the label of the Phenol Red or Buffer 7 Solution.
- 10) Press OK to save the new calibration or Esc to abort without saving.
- 11) Press Esc to return to the main display.

ORP (Redox) Calibration

ORP is calibrated using an ORP Standard Solution. A standard closest to the normal operating value should be used for calibration.

- 1) Shut off the water inlet and outlet from the flow cell
- 2) Remove the ORP sensor and (PT-100) temperature probe from the flow cell.
- 3) Wipe sensor probe with a dry cloth and submerge it and the temperature probe into a cup with the ORP Standard Solution and wait for the reading to stabilize.

Note: The reading will not stabilize if the temperature probe is not also in the buffer solution

- 4) Press Menu until ORP Calibrated to appears in the LCD display.
- 5) Press OK.
- 6) Enter the password. Press the up arrow or down arrow until the password is reached.
- 7) Press OK.
- 8) Press OK again.
- 9) Press the up arrow or down arrow until the value is the same as the value printed on the label of the standard solution.
- 10) Press OK to save the new calibration or Esc to abort without saving.
- 11) Press Esc to return to the main display.

Note: When the HydroGuard is initially turned on, the pH and ORP readings will continue to rise for the first 24-48 hours. If calibration is required, it is best to wait until the readings have stabilized or recalibrate when the readings have stabilized.

Temperature Calibration

Take a sample of water from the flow cell

- 1) Insert a digital thermometer into the sample
- 2) Wait for the thermometer reading to stabilize
- 3) Press Menu until Temperature Calibrated to appears in the LCD display.
- 4) Press OK.
- 5) Enter the password. Press the up arrow or down arrow until the password is reached.
- 6) Press OK.
- 7) The value that appears is the last calibrated value.
- 8) Press OK again.
- 9) Press the up arrow or down arrow until the value is the same as the independent digital thermometer.
- 10) Press OK to save the new calibration or Esc to abort without saving.
- 11) Press Esc to return to the main display.

6.3.3 Shut-down and Winterizing

- 1) Remove the probe from the flow cell
- 2) Fill the rubber caps (that were on the new probes) with tap water or preferably KCl (potassium chloride) solution and insert over the end of each probe (DO NOT use DI water).
- 3) Screw the plastic cap over the top of each probe to protect the connector.
- 4) Store in a safe location that will not drop below freezing, preferably in the original probe box for additional protection.

6.3.4 Replacing Sensors

Replacing the pH or ORP sensor

- 1) Turn off the inlet and outlet water to the flow cell and the power to the analyzer.
- 2) Open the doors of both the analyzing module and the control module.
- 3) Locate the sensor in the flow cell that is to be replaced. The specific sensor may be identified by the label on the wire or by tracing the wire from the control panel back to the sensor.
- 4) Remove old sensor from flow cell
 - a) Unplug the sensor's wires from the sensor, by grabbing the connector at the top end of the sensor and unscrewing the connector.
 - b) Unscrew the sensor from the flow cell
 - c) Pull the sensor up until its glass tube clears the hole.
- 5) Install new Sensor
 - a) Open the replacement sensor's box, and remove the sensor by the metal connector.
 - b) Remove the plastic cap on the glass end of the probe
 - c) Hold the sensor by its metal connector, with the glass tube pointing down, and insert the glass tube into a hole in flow cell.
 - d) Screw the probe into place. DO NOT OVERTIGHTEN
 - e) Attach the sensor wire onto the probe.

Replacing the Temperature Probe

- 1) Turn off the inlet and outlet water to the flow cell and the power to the analyzer.
- 2) Open the doors of both the analyzing module and the control module.
- 3) Remove the four (4) wires from the temperature probe in the control module.

- 4) Remove old sensor from reading cell:
 - a) Unscrew the compression fitting from the temperature probe
 - b) Pull the probe up until it clears the fitting.
- 5) Install new sensor:
 - a) Insert the temperature probe into the fitting
 - b) Screw the compression fitting around the probe.
 - c) Connect wires to pH, ORP, Temp module following color coding

Replacing pH, Redox, and Temperature Module

Disconnect the power supply to the unit before opening the control unit.

- 1) Disconnect the flat cable plug from the card.
- 2) Unscrew the four (4) mounting screws.
- 3) Put in the new card and tighten the 4 mounting screws.
- 4) Connect the flat cable plug to the card.

6.4 Turbidity Measurements

6.4.1 Installation

If the HydroGuard system was ordered with the Turbidity pre-installed some of these steps may have been completed in the factory.

Supplied Components

- Turbidity Input Module (electronics card)
- 250 mm flat cable
- Turbidity Sensor (wiper optional)
- Turbidity Flow Cell (bubble remover optional)
- Flow Cell Mounting Bracket

Caution: Prior to opening the analyzer or installing any electrical components, turn off all power supplies to the analyzer

There are five (5) wires, contained in a single cord, from the sensor that must be connected to the analyzer. The standard wire length is 22 ft (7m), and may be cut or extended up to 650 ft (200m) as needed. The turbidity flow cell and sensor must be securely mounted using appropriate hardware for the mounting location. Unfiltered water will need to be supplied to the turbidity flow cell at a flow between 0.25 to 1 GPM and less than 30 psi (2 bar).

Hardware and Plumbing Installation

- 1) Mount the Turbidity Flow Cell, using the supplied bracket (or other mounting hardware as appropriate) such that the inlet and outlet ports are horizontal and the flow tube extends down.
- 2) Insert the sensor into the opening of the flow tube, ensuring that the notch in the top of the opening matches the rod on the sensor.
- 3) Hand-tighten the connector to secure the sensor and seal the turbidity flow cell.
- 4) Connect the water supply to the turbidity flow cell. Follow the flow indicated by the arrow on the flow cell.



A



B

Figure 6: A. Turbidity Sensor and Flow Cell without bubble remover
B. Flow Cell with bubble remover

The flow rate should be between 0.25 and 1 GPM (15-60 gal/hr or 50-225 L/hr) and the pressure should not exceed 30psi (2 bar). The inlet and outlet connections are ¼" FNPT.

Electrical Installation

- 1) Install the Turbidity Module (electronics card) on the inside, bottom of the control panel door using the supplied screws.
- 2) Connect the turbidity module to the I/O module using the supplied ribbon cable and any open connector (the connectors on both boards operate in parallel).
- 3) Pass the sensor cable through an open glad on the bottom of the analyzer.
- 4) Connect the wires from the sensor cable to the terminal block on the lower left corner of the Turbidity Module, following the color order indicated on the module.

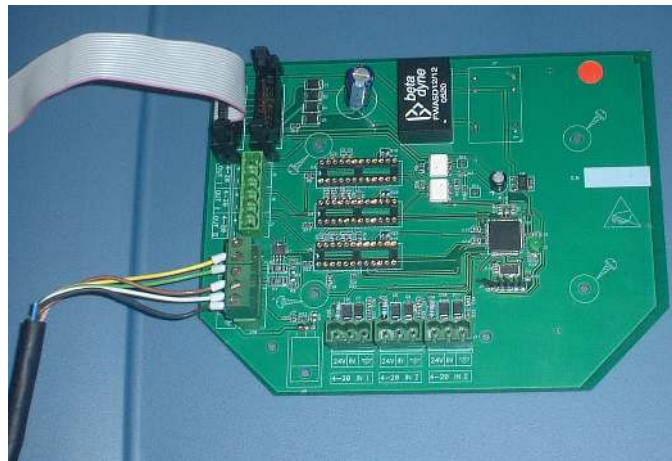

Figure 7: Connecting Turbidity Sensor to Turbidity Module

The sensor cable may be cut or extended up to a maximum distance of 650 feet (200m) as needed.

If the turbidity relay is not going to be connected to any external equipment, the installation is complete. If the relay will be used to operate equipment based on the turbidity set point, the following steps will need to be followed:

6.4.2 Relay Wiring and Use

Wiring of the Turbidity Relay (NTU relay) is identical to wiring of all other relays and should be connected to a dependent (interlocked) power supply to prevent operation of equipment when the water supply is not active. Likewise, it operates based on closed-loop control.

The line (live) wire of the pump-dependent power source connects to the connection labeled Common (C) on the NTU relay. The line wire of the controlled external turbidity equipment is connected to the normally open (NO) or normally closed (NC) connection of each relay as appropriate. Normally Open means that the relay will be open (i.e. no power from the relay) until the analyzer calls for power; Normally Closed means that the relay will be closed (i.e. power from the relay) until the analyzer calls to stop power.

- 1) Turn OFF all power sources to the analyzer.
- 2) Connect the earth ground wire of the power supply to the ground return wire from the controlled external turbidity equipment.
- 3) Connect the neutral wire of the power supply to the neutral wire from the controlled external turbidity equipment.
- 4) Connect the line (live) wire of the power supply to the connector marked 'C' (common) on the NTU terminal block.
- 5) Connect the line (live) wire of the controlled external turbidity equipment to the normally open (NO) or normally closed (NC) connection on the NTU terminal block.

Caution: Each relay connection is limited to 4 amps, to prevent overheating. The relays may show a higher rating but do not connect equipment exceeding 4 amps.

Relay and External Equipment Operation

The relay will operate in an ON/OFF mode. Whenever the measured turbidity is below the set point, the relay will remain open (no power to normally open connection). Whenever the measured turbidity is above the turbidity set point, the relay will close (power will be supplied to the normally open connection).

If the measured turbidity is above the turbidity high alarm, the alarm on the analyzer will be activated. The NTU relay will remain closed (power to the normally open connection) even during alarm.

6.4.3 First Time Set-up and General Operation

Although the turbidity unit is connected, it will not operate until it is set-up in the analyzer menu.

Operator Menu

If the NTU relay is connected to external equipment:

- 1) Press Menu until "Turbidity Set Point" appears on the display and press OK
- 2) Enter the operator or technician password and press OK
- 3) Enter the turbidity set point value and press OK

With or without the NTU relay connected to external equipment:

- 4) Press Menu until "Turbidity High Alarm" appears on the display and press OK

- 5) Enter the operator or technician password and press OK
- 6) Enter the turbidity high alarm value and press OK

Technical Menu

- 1) Press Menu to enter the Operator Menu and then Press up and down together to enter the technical menu
- 2) Press Menu until "Turbidity ON/OFF" appears in the display and press OK
- 3) Enter the technician password and press OK
- 4) Press up to turn the turbidity sensor ON and press OK
- 5) Press Menu until "Turbidity Wiper Interval" appears in the display and press OK
- 6) Enter the technician password and press OK
- 7) Enter the wiper interval (2 minutes is recommended) and press OK

The turbidity unit should now be active. Confirm that the turbidity value appears on the LCD display. If it is not active, perform a system reset.

6.4.4 Routine Maintenance

Turbidity Calibration

- 1) Take a sample of water from the flow cell
- 2) Test the sample using an accurate digital turbidity meter
- 3) Press Menu until NTUI Calibrated to or NTU_h Calibrated to appears in the LCD display.

If calibrating below 1.0 NTU use NTUI (low) if calibrating above 1.0 NTU use NTU_h (high).

- 4) Press OK.
- 5) Enter the password. Press the up arrow or down arrow until the password is reached.
- 6) Press OK.
- 7) The value that appears is the last calibrated value.
- 8) Press OK again.
- 9) Press the up arrow or down arrow until the value is the same as the independent digital turbidity meter.
- 10) Press OK to save the new calibration or Esc to abort without saving.
- 11) Press Esc to return to the main display.

Note: Only 1 Turbidity calibration will be active. If the measured Turbidity is less than 1.0, only the NTUI calibration will be active; if the turbidity is greater than 1.0, only the NTU_h calibration will be active.

6.4.5 Cleaning the Turbidity Sensor

The turbidity meter will need to be periodically cleaned to ensure proper operation and reliability. The cleaning frequency will depend on the water source being tested. The meter should be cleaned whenever the measurement accuracy is questionable and before calibration.

- 1) Turn off power to the analyzer.
- 2) Shut off the flow to the turbidity flow cell and remove the turbidity meter.
- 3) Rinse out the flow assembly with clean water to remove any sediment that may have been trapped in the flow cell.
- 4) Wash the turbidity meter under clean water and a cloth to remove any debris and oil. Be careful not to scratch the sensor covers.
- 5) If installed, inspect the wiper for signs of wear and replace if necessary.
- 6) Reinstall the meter and turn the flow back to the meter.
- 7) Confirm that the meter is operating properly and that the flow cell is sealed.

6.4.6 Shut-down and Winterizing

- 8) Disable the Turbidity measurement in the technician menu
- 9) Shut off the flow of water to the turbidity flow cell
- 10) Open the drain at the bottom of the flow cell to drain all water
- 11) If temperatures will drop below freezing, remove the turbidity sensor and store in a safe location where temperatures will not drop below freezing.

6.4.7 Replacing Components

Replacing the Turbidity Meter

- 1) Turn off the inlet and outlet water to the flow cell and the power to the analyzer.
- 2) Open the door of the control module.
- 3) Remove the 5 wires from the bottom of the Turbidity input module
- 4) Remove the meter from the flow cell by unscrewing the cap and pulling gently
- 5) Install the new meter in the flow cell
- 6) Route the wires back to the turbidity module and reconnect the 5 wires following the color coding on the module.
- 7) Restart the flow and turn the power on
- 8) Confirm that proper operation has been restored

Replacing Turbidity Input Module

Disconnect the power supply to the unit before opening the control unit.

- 1) Disconnect the flat cable plug from the card.
- 2) Disconnect all terminal blocks
- 3) Unscrew the four (4) mounting screws.
- 4) Put in the new card and tighten the 4 mounting screws.
- 5) Connect the flat cable plug to the card
- 6) Reconnect the terminal blocks

6.5 Conductivity Measurements

6.5.1 Installation

If the HydroGuard system was ordered with the Conductivity pre-installed some of these steps will have been completed in the factory.

Supplied Components

- Conductivity 4-20 input Module (electronics card)
- 150mm Flat Cable (ribbon cable)
- Conductivity meter
- Conductivity flow cell

Caution: Prior to opening the analyzer or installing any electrical components, turn off all power supplies to the analyzer

- 1) Attach the module to the inside of the control panel door below the control panel module using the 4 supplied screws.
- 2) Attach the ribbon cable from the conductivity module to any open connector on the I/O module.

- 3) Mount the conductivity flow cell and meter on a solid wall or surface using appropriate hardware (not supplied). Make sure that the distance is less than 15m (45 feet) from the HydroGuard analyzer.
- 4) Connect a water supply of no greater than 2 bar (30 psi) to the inlet fitting using 6mm tubing. It may be a new separate water supply or a line tapped from the main analyzer water supply before the pre-filter. Larger tubing may be used if the fitting is replaced to accept the new tubing.
- 5) Connect a 6mm water outline line to the outlet fitting and connect to:
 - b. The water system at least 5 psi (0.3 bar) lower than the inlet water supply or
 - c. The pre-filter of the HydroGuard analyzer.
- 6) Route the conductivity meter wire through an open gland on the bottom of the analyzer
- 7) Connect the wires to an open 4-20mA input on the bottom of the 4-20 module
- 8) Connect 24V from the meter to 24V on the module
- 9) Connect mS from the meter to IN on the module
- 10) Connect GND from the meter to ground (symbol) on the module

6.5.2 First Time Set-up and General Operation

For Output of the conductivity measurement, see internal or external 4-20mA module sections to configure the output in your specific HydroGuard analyzer.

6.5.3 Routine Maintenance

Conductivity Calibration

Must be conducted when process is stable, specifically temperature should be within normal operating range.

- 1) Test a sample of water with an accurate external conductivity meter
- 2) Use the calibration adjustment screw to increase or decrease the conductivity, making very small changes
- 3) Wait for the adjustment to take effect before making additional changes

6.5.4 Cleaning the Conductivity Meter

Routine cleaning of the conductivity meter will ensure long-term reliability. The frequency of cleaning will depend on the water source being tested and should be conducted whenever there is significant visible dirt, the measurement accuracy is affected, or before the meter is calibrated.

- 4) Shut off the flow of water to the conductivity flow cell and remove the meter.
- 5) Wash the meter under a jet of water to remove the debris.
- 6) Use a soft cloth to remove any additional debris and oil.
- 7) Replace the meter and restore flow to the flow cell.

6.5.5 Shut-down and Winterizing

- 1) Shut off the flow of water to the conductivity flow cell
- 2) Drain the water from the flow cell
- 3) If temperatures will drop below freezing, remove the conductivity sensor and store in a safe location where temperatures will not drop below freezing.

6.5.6 Replacing Components

6.5.7 Replacing the Conductivity Meter

- 1) Turn off the inlet and outlet water to the flow cell and the power to the analyzer.
- 2) Open the door of the control module.
- 3) Remove the wires from the bottom of the Conductivity input module
- 4) Remove the meter from the flow cell by unscrewing the cap and pulling gently
- 5) Install the new meter in the flow cell
- 6) Route the wires back to the conductivity module and reconnect the wires to the 4-20 input module.
- 7) Restart the flow and turn the power on
- 8) Confirm that proper operation has been restored

Replacing Conductivity Input Module

Disconnect the power supply to the unit before opening the control unit.

- 1) Disconnect the flat cable plug from the card.
- 2) Disconnect all terminal blocks
- 3) Unscrew the four (4) mounting screws.
- 4) Put in the new card and tighten the 4 mounting screws.
- 5) Connect the flat cable plug to the card.
- 6) Reconnect the terminal blocks

6.6 Flow Meter

Blue I Water Technologies does not supply flow meters; only input connections and display.

6.6.1 Installation

Required Components

- Flow meter – frequency or 4-20
- 4-20 input module if using 4-20 flow meter
- 150 mm flat cable if using 4-20 input module

Prior to opening the analyzer or installing any electrical components, turn off all power supplies to the analyzer

Frequency Output Flow Meter

A flow meter with either two (2) or three (3) wires for a frequency output can be connected to the input switch section on the I/O module.

Installation

- 1) Install the flow meter following the manufacturer directions. Be sure to install close enough to HydroGuard that the wires will reach.
- 2) Pass the flow sensor cable through an open glad on the bottom of the analyzer.
- 3) Connect the two or three wires from the sensor cable to the input switch terminal block on the lower right corner of the I/O Module.

Although the flow meter is connected, it will not operate until it is set-up in the analyzer menu.

- 4) Press Menu until "Flow Low Limit" appears and enter the low flow value (the flow value which will cause an alarm and will disable any direct chemical dosing).
- 5) Press Menu again and "K-factor" appears. Enter the k-factor for the flow meter being used (should be on paperwork with flow meter).
- 6) Press Up + Down arrows together and then press Menu until "Flow Rate m3/hr" appears and select the flow units of m3/hr or GPM.

4-20 Output Flow Meter

Any flow meter with a 4-20mA output can be connected to the analyzer's internal 4-20 input module

- 1) Install the flow meter as per the manufacturer directions.
- 2) Pass the flow sensor cable through an open glad on the bottom of the analyzer.
- 3) Connect the 4-20mA output wires from the flow meter to the middle 4-20mA Input connection on the input module.

Although the flow meter is connected, it will not operate until it is set-up in the analyzer menu.

- 4) Press Menu until "Flow Low Limit" appears and enter the low flow value (the flow value which will cause an alarm and will disable any direct chemical dosing).
- 5) Press Up + Down arrows together and then press Menu until "Flow Rate m3/hr" appears and select the flow units of m3/hr or GPM.
- 6) Press Menu until "Max flow Range" appears and enter the maximum flow rate (flow rate at 20mA output). The minimum flow rate (flow rate at 4mA output) is assumed to be zero.

The flow meter should now be active. Confirm that the flow rate appears on the LCD display. If it is not active, perform a system reset.

6.6.2 Routine Maintenance and Troubleshooting

Follow manufacture's recommendations for maintenance procedures and any troubleshooting issues.

6.7 Communication Options

6.7.1 External 4 to 20mA Outputs

Overview

The 4 to 20 mA output provides a connection of the HydroGuard water quality analyzer to any external monitoring or control system. For each parameter, an output signal is transmitted and the strength of the signal (in mA) can be simply correlated to the actual parameter value. Likewise, specific alarm information may also be transmitted to alert personnel of a problem not related to the output parameters.

Installation

Required Parts

The 4 to 20mA module upgrade includes two (2) main components that are supplied with the upgrade:

- External 4 to 20 module case
- 4 to 20 module (electronics card)

To complete the installation a few additional components, not supplied with the upgrade will be needed:

- Hardware to attach the external module case to a wall or other secure structure.
- 110-115 or 220-230V AC power supply with 3 wires
- A 2-wire cable for connection between the module and analyzer
- A 2-wire cable for each output channel/parameter

Hardware Installation

- 1) The external case has 4 mounting brackets on the back. All 4 should be used to securely attach to the wall.
- 2) Mark the location of each screw hole and drill a hole for a screw anchor.
- 3) Thread the screws almost completely into the anchor leaving about $\frac{1}{4}$ " (6 mm) of thread exposed.
- 4) Attach the external case to the screws
- 5) Adjust the screw depth to securely fasten to the wall

Electrical Installation

The 4 to 20 mA module requires a separate power supply in order to operate. The 2-wire connection to the analyzer is for communication only and does not supply any power.

The Module Power Supply may be connected to either 110-120 or 220-240VAC 50/60Hz. Switching between voltages is accomplished by changing two (2) jumpers located above the main power connection, to the left of the transformer. For 110-120VAC, a 1amp fuse should be used; for 220-240VAC, a 0.5amp fuse should be used. These changes must be completed prior to wiring.

Caution: Before making a connection to a power source, confirm that both jumpers are located on the correct voltage and that the appropriate fuse is in place.

Connecting Main Power and Analyzer Communication

- 1) Verify that the power switch or circuit breaker to the non-dependent power source is off.
- 2) Locate the power supply connection.
- 3) Connect the line (live) wire to the electronic board connector marked Line.
- 4) Connect the neutral wire to the electronic board connector marked Neutral.
- 5) Connect the earth wire to the electronic board connector marked Ground.
- 6) Locate the RS485 connections on the analyzer control panel (electronics card on the analyzer door) and the 4 to 20 mA module.
- 7) Connect the 2-wire cable from the RS485 connection on the analyzer to the RS485 connection on the 4 to 20 mA module.
 - a) Connect the '+' wire from the analyzer to the 'A' connection on the module
 - b) Connect the '-' wire from the analyzer to the 'B' connection on the module
- 8) Turn on electrical power only after all electrical connections have been completed.

Confirming Operation and Communication

Prior to connecting to the external monitoring or control system, it is best to confirm that all desired outputs are working properly using a digital multi-meter. This must be done without output wires connected to an external system.

- 1) Set the multi-meter to measure current and connect the multi-meter to an active output (an output is inactive if it does not have a chipset installed next to the terminal block).
- 2) Record the current in mA.
- 3) Confirm that the value is accurate using, Equation 1.
- 4) Repeat for each active output.

$$MeasuredValue = \frac{(mA) * (Fullscale)}{16} + MinimumValue$$

or

$$mA = \frac{(16) * (MeasuredValue)}{FullScale} + 4$$

mA = milliamp output value

Full Scale = Max Value - Min Value (in case of Min is zero, it's the max value)

Equation 1: Determining Parameter Value from mA output

Connecting to External Monitoring System

- 1) Connect two wires from the active output to the appropriate connection on the external system
- 2) Repeat for each active output
- 3) If an active output (output with a chipset installed) is not to be used, place a jumper wire between the contacts.
- 4) For alarm notification
 - a) Connect two wires to the appropriate dry contact
 - i) Connection between C and Nc will have contact unless alarm
 - ii) Connection between C and No will only have contact during alarm
 - b) Repeat for each alarm

Connections on 4 to 20mA Module

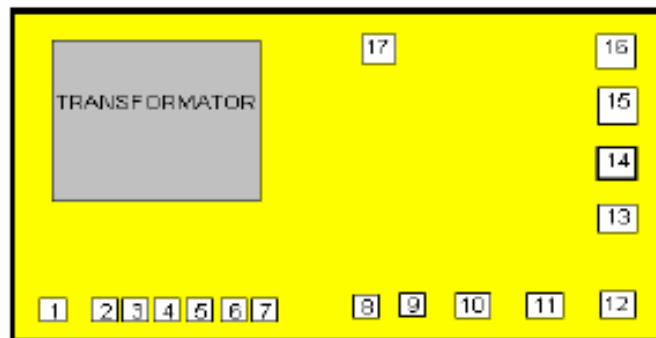

Figure 8: 4 to 20 mA Output Module Electrical connections

1. Power Input 110-115 or 220-230VAC 50/60 Hz

Alarm (Dry Contacts)

2. No Flow
3. Unclean Cell
4. No Communication with the Colorimeter
5. Reagents Close to completion
6. No Reagents
7. External Disconnected

Communication Connection

8. RS485 Communication Terminal Block
17. RS 232 Communication Terminal Block

Communication Connection

9. Free Cl	4mA = 0	20mA = 9.99
10. pH	4mA = 0	20mA = 9.99
11. ORP	4mA = 0	20mA = 999
12. Temp	4mA = 0	20mA = 50 °C or 212 °F
13. NTU	4mA = 0	20mA = 9.99
14. Flow Rate	4mA = 0	20mA = 200 m ³ /hr
15. Total Cl	4mA = 0	20mA = 9.99
16. Conductivity	4mA = 0	20mA = 2000 uS

Troubleshooting

There are a few indicator lights on the 4 to 20 mA module to aid in troubleshooting. The following conditions are possible:

Green Light

- ON – 4 to 20 mA module is powered
- OFF – 4 to 20 mA module is not powered

Red Light

- ON – One or more of the outputs is not connected (use jumper wire on unused outputs)
- Flashing – No communication between 4 to 20 mA module and analyzer
- OFF – Communication and Outputs are working properly

6.7.2 Internal 4 to 20mA Output

Installation

Required Parts

- Internal 4-20mA Module (electronics card)
- 250mm Flat Cable (ribbon cable)

To complete the installation a 2-wire cable for each output channel/parameter will also be required.

Hardware Installation

- 1) Attach the 4 to 20 module to the inside of the control panel door below the control panel module using the 4 supplied screws.

- 2) Attach the ribbon cable from the 4 to 20 module to any open connector on the I/O module.

Electrical Installation

The 4 to 20 mA module is powered through the ribbon cable and does not require a separate electrical supply as the external module.

Software Set-up

- 1) Go to "4-20mA Output Settings" menu and press OK
- 2) Enter the technician password and press OK
- 3) Select the channel (1 to 4) and press
- 4) Press OK and Select the parameter for that channel (Free Cl, Total Cl, pH, etc.)
- 5) Press Menu and then OK to set the minimum range (4mA value)
- 6) Press Menu and then OK to set the maximum range (20mA value)
- 7) Optional: Press Menu and then OK to set the test value (to be used for troubleshooting purposes or initial tests)
- 8) Press Escape to return to the set-up menu and repeat above for remaining channels
- 9) Press Menu to go to "On Alarm go to" menu and then OK to set the error value (output value in case of measurement or communication error) from the following options:
 - 2 mA
 - 4 mA
 - 20 mA
 - Hold Last Value

This is the 4-20mA output value that will indicate whenever an alarm condition exists or communication between the analyzer and 4-20 module is interrupted.

Confirming Operation and Communication

Prior to connecting to the external monitoring or control system, it is best to confirm that all desired outputs are working properly using a digital multi-meter. This must be done without output wires connected to an external system.

- 1) Set the multi-meter to measure current and connect the multi-meter to an active output (an output is inactive if it does not have a chipset installed next to the terminal block).
- 2) Record the current in mA.
- 3) Confirm that the value is accurate using, Equation 1.
- 4) Repeat for each active output.

$$MeasuredValue = \frac{(mA) * (Fullscale)}{16} + MinimumValue$$

or

$$mA = \frac{(16) * (MeasuredValue)}{FullScale} + 4$$

mA = milliamp output value

Full Scale = Max Value - Min Value (in case of Min is zero, it's the max value)

Equation 1: Determining Parameter Value from mA output

Connecting to External Monitoring System

- 1) Connect two wires from the active output to the appropriate connection on the external system
- 2) Repeat for each active output
- 3) If an active output (output with a chipset installed) is not to be used, place a jumper wire between the contacts.

7 Appendix A: Relays and Closed-Loop Control

There are 6 dry-contact relays on the I/O module. Five of the relays may be used for direct control of closed loop systems. All of the relays may be used as dry-contacts, and will operate based on the settings, specifically the set-points, selected in the operator menu.

7.1 *Connecting external equipment to the Relays*

This is only required if the relays are being used to power and control external dosing equipment. The relays will act as dry contacts if no power is supplied. A dependent power supply should be used such that no equipment will be activated unless the process line has flow.

7.1.1 Wiring to Dosing Systems

HydroGuard controls chemical dosing systems using a series of electronic relays that start and stop the dosing pumps. Each relay opens and closes a switch that activates a separate pump or piece of equipment.

The line (live) wire of the dependent power source connects to the connection labeled Common on each relay. The line wire of each controlled system is connected to the normally open (NO) or normally closed (NC) connection of each relay as appropriate. Normally Open means that the relay will be open (i.e. no power from the relay) until the controller calls for power; Normally Closed means that the relay will be closed (i.e. power from the relay) until the controller calls to stop power.

- 1) Verify that the power switch or circuit breaker to the dependent power source is off.
- 2) Connect the earth wire to the ground return wire from each of the external dosing systems.
- 3) Connect the neutral wire to the return wire from each of the external dosing systems.
- 4) Connect the line (live) wire to the connector marked Common of each active relay.

Caution: Each relay connection is limited to 4 amps, to prevent overheating. The relays may show a higher rating but do not connect equipment exceeding 4 amps.

The following table lists the relays and the dosing systems they control:

Relay	Control
Cl 1	Main chlorine system. On/Off or proportional. Proportional controls pulse length or pulse frequency (PL/PF).
Cl 2	Secondary chlorine system (On/Off only – no proportional control)
pH	Acid or base dosing. On/Off or proportional. Proportional controls pulse length or pulse frequency (PL/PF).
NTU	Nephelometric Turbidity Units – Controls the injection of flocculants or coagulants. Used only with the optional turbidity module.
Alarm	Activates an external alarm when certain alarm types are registered and after the alarm delay time has expired.
Temperature	Controls water temperature by activating the water heating system.

7.1.2 Proportional Control Overview

HydroGuard controls dosing proportionally. This method sets dosing rates in relation to how far current chemical levels are from the set point. The dosing rates gradually decrease as chemical levels get closer to the set point.

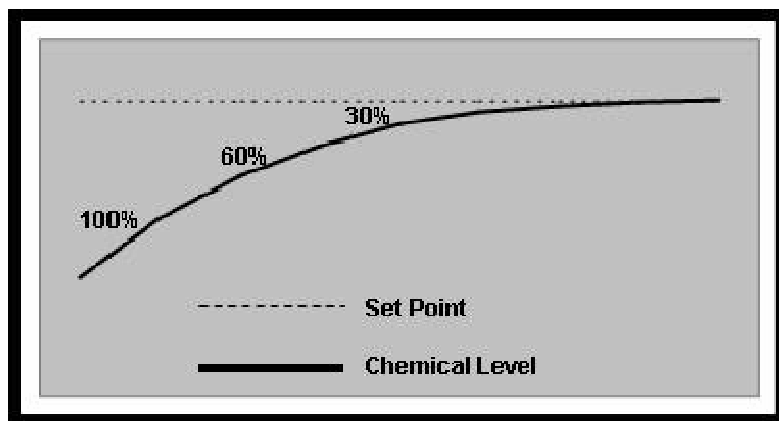

Figure 9: Proportional Control of Chemical Dosing

If water chemical levels are far below the set point, HydroGuard will operate the dosing systems to operate at full speed (100%). As the controller senses chemical levels rising and getting closer to the set point, it will control the dosing systems to slow down to a lower speed (i.e. 60%). As chemical levels get even closer to the set point, the dosing system will slow down even more (i.e. 30%), and so on, until the chemical level gets to the set point.

The % of the time on is explained by the following equation with chlorine as an example:

$$\%time_{on} = \left[\frac{(\text{setpoint} - \text{measured})}{\text{setpoint}} \right] \bullet P_{factor}$$

In this example, the Cl set-point and measured values are:

Cl Set Point	Cl Measured
2.0	1.8

If the P-factor is changed, the percentage of the pump cycle that will be on (% time on) changes as follows:

Pfactor	% Time ON
0.1	1%
0.5	5%
1	10%
5	50%
10	100%

The range for P-factor for Cl and pH are presented in the table below.

Cl p Factor	50	On/Off control
	0.1	Very proportional and slow dosing
pH p Factor	100	On/Off control
	0.1	Very proportional and slow dosing

7.1.3 Setting Proportional Factor

Proportional control of chemical dosing requires configuration according to various factors. The primary factors are the ratio between the system size and the rate the chemical dosing systems can feed chemicals, and the delay time between when the chemical level changes and when it is sensed by the controller.

In large systems, changes in chemical levels occur slowly. The dosing systems must feed large amounts of chemicals for a long period of time in order for a change to be noticed. The chemicals also disperse slowly in larger systems. Smaller systems, on the other hand, react much more quickly.

The length of time between the change and when the controller identifies the change also affects proportional control. The controller can only identify water chemical levels after they have been distributed throughout the system and have returned to the analyzer. This may be a long time after the chemicals were released into the water. The controller, therefore, recognizes the chemical levels from dosing settings in the past. The dosing systems continue feeding chemicals during this delay, causing chemical levels to pass the set point, resulting in fluctuations.

To prevent these fluctuations, the controller must reduce chemical dosing rates as it senses that chemical levels are approaching the set point, taking the delay into account. The controller should also not overcompensate for the delay, which would cause chemical levels.

In short, the larger the water system, the higher the p-factor.

7.1.4 Setting Pump Period

Pump period is a single cycle during which the dosing pump operates and then rests. Proportional control divides the pump period into two distinct phases: active and at rest. In general it is recommended to operate in a short cycle, i.e., 00:30 Sec. For large systems, or if you activate solenoid valves, you may consider longer pump periods.

7.1.5 Step By Step Proportional Settings

- 1) Finish the installation of all controllers (electrical, water, feeding systems, and electrodes).
- 2) Calibrate the controller to the water chemical values at the sample point.

- 3) Set the proportional factor and the pump period of the chlorine and the pH at an initial setting.
- 4) Let the controller operate the chlorinator and the pH correction devices and make sure that chemicals are injected into the water.
- 5) Watch the chlorine and pH as they change. We recommend that you record the values frequently so that the process is closely monitored.
 - a) If the values greatly exceed the set point, you need to decrease the proportional factor.
 - b) If it takes too long to get to the set point, you need to increase the proportional factor.

Note: In large systems the delay time between injection of the chemicals and receiving the change in the controller can be very long (30 minutes or more).

8 Appendix B: Technical Specifications

Mechanical Data	Dimensions (analyzer)	26" x 13" x 5.5" (W x H x D) 668mm x 332mm x 140mm
	Dimensions (mounting board)	31.5" x 21.5" x 6" (W x H x D) 800mm x 546mm x 152mm
	Cable entries	Pg 9 Cable Glands
	Ingress protection	IP 65 (NEMA 4 equivalent)
	Max. permissible ambient temperature	15 °F to 130 °F (-10 °C to 55 °C)
	Weight	Approx. 20 lbs. (9kg)
Electrical connection	Power supply	100-120 or 220-240V 50Hz/60Hz
	Power consumption	Approx 80 VA
	Power supply for RTC Memory	3.6V Lithium Battery
Data Serial output	RS 485	Standard
Signal output	4-20ma	optional
Relays (dry contact)	1. Chlorine set point 1	Max 4A; Max 240VAC
	2. Chlorine set point 2	Max 4A; Max 240VAC
	3. pH	Max 4A; Max 240VAC
	4. Turbidity control	Max 4A; Max 240VAC
	5. General Alarm	Max 4A; Max 240VAC
	6. Temperature control	Max 4A; Max 240VAC
Display	Measured value displays	Free Chlorine, Total Chlorine, pH, ORP, Turbidity, Conductivity, Temperature, and Flow
	LCD with background light	For all measured values, menus, and alarms
Flow	Sensor	Rotating flow Switch
	Output signal	Dry Contact
	Input Pressure	7 to 15 psi (0.5 to 1 bar) without regulator; max of 45 psi (3 bar) with regulator adjusted to 0.5 bar
	Outlet Pressure	5 to 10 psi (0.3 to 0.7 bar)
	Minimum Flow Rate	0.25 GPM (60 L/hr)

pH measurement	Display range	4 to 10
	Sensor	Ceramic diaphragm and gel filling
	Input impedance	$0.5 \times 10^{12} \Omega$
ORP (Redox) measurement	Display range	0-13000mv
	Sensor	Ceramic diaphragm and gel filling
	Input impedance	$0.5 \times 10^{12} \Omega$
Chlorine measurement	Sensor	Colorimetric Multi Spectrum sensor
	Cell cleaning	Automatic self cleaning mechanism (patent Pending)
	Mixing Technology	Inner solenoid activated active mixer
	Display range	0-10ppm
	Reagent containers	500 mL
	Reagent type	DPD 1 and/or DPD3, or DPD4
	Reagent use/sample	Approximately 0.03 mL
	Measuring interval	2 to 10 minutes (2:30 to 10 for FC + TC units)
	Reagent replacement interval	1-2 month
	Reagent Shelf life	1 year unmixed 2 months mixed
Temperature measurement	Sensor	PT-100
	Measuring range	32 to 158 °F (0 to 50 °C)
pH value control	Closed Loop Control function	On/Off P or PI
	Proportional band	yes
	Characteristics	Normal / Inverted
	Set value function	Pulse Length proportional controller Pulse Frequency proportional controller
ORP (Redox) value control	Control Function	High Alarm as chlorine override
Chlorine control #1	Closed Loop Control function	On/Off or PI
	Proportional band	yes
	Set value function	Pulse Length proportional controller Pulse Frequency proportional controller
Chlorine control #2	Closed Loop Control function	On/Off
	Proportional band	no
	Integral action time	no
Data logger	Memory	256K
	Lines	1000
	Recording interval	1-360 min
	Event logger	yes
	Total relay on time	yes
Security	Operation Password	Yes
	Technician Password	Yes

No part of this publication may be reproduced, transmitted, transcribed, stored in a retrieval system, or translated into any language or any computer language, in any form or by any third party, without the prior written permission of Blue I Water Technologies Ltd.

Trademarks and Patents

HydroGuard is the Registered trademark of Blue I Water Technologies Ltd.
Patents issued and pending at the time of this printing

Disclaimer

Blue I Water Technologies Ltd. does not accept any responsibility for any damage caused to its products by unauthorized personnel. Use of non-Blue I Water Technologies' reagents and/or replacement parts will void all warranties.